

Prosilica GX

6600



- 240 MBps with dual interface LAG technology
- 3-axis motorized lens control
- 4 fps at full resolution
- ON Semi KAI-29050 sensor

Shift up to double speed

The fastest Gigabit Ethernet cameras in the world -
240MB/s

Prosilica GX 6600 with ON Semi KAI-29050 runs 4.0 frames per second at 28.8 MP resolution.

Prosilica GX cameras are fast, compact machine vision cameras with Gigabit Ethernet interface (GigE Vision®). The GX-Series have two screw-captivated Gigabit Ethernet ports configured as a Link Aggregation Group (LAG) to provide a sustained maximum data rate of 240 MBytes per second. Prosilica GX can also work at half the bandwidth (120 MB/s) using a single cable.

- Very Fast - 240 MB/s
- 3-axis motorized lens control and video-type autoiris
- Single or dual Ethernet port operation
- 1 to 29 Megapixel
- Fast frame rates upto 112 fps
- OnSemi KAI or Sony quad-tap CCD sensors
- Modular options available

Specifications

Interface	IEEE 802.3 1000baseT
Resolution	6576 (H) × 4384 (V)
Sensor	ON Semi KAI-29050
Sensor type	CCD Progressive
Shutter mode	GS (Global shutter)
Sensor size	Type 35 mm
Pixel size	5.5 μm × 5.5 μm
Lens mount (default)	F-Mount
Max. frame rate at full resolution	4 fps
ADC	14 Bit
Image buffer (RAM)	128 MByte

Output

Bit depth	14-bit (monochrome); 12-bit (color)
Monochrome pixel formats	Mono8, Mono12, Mono12Packed, Mono14
RGB color pixel formats	RGB8Packed, BGR8Packed, RGBA8Packed, BGRA8Packed, RGB12Packed
Raw pixel formats	BayerGR8, BayerGR12, BayerGR12Packed

General purpose inputs/outputs (GPIOs)

Opto-isolated I/Os	2 inputs, 4 outputs
RS232	1

Operating conditions/dimensions

Operating temperature	0 °C to +50 °C ambient (without condensation)
Power requirements (DC)	10 to 24 VDC
Power consumption	6.1 W at 12 VDC (Single GigE Mode); 7.6 W at 12 VDC (Dual GigE Mode)
Mass	510 g
Body dimensions (L × W × H in mm)	136.6 × 59.7 × 59.7 (including connectors and lens mount)

Quantum efficiency

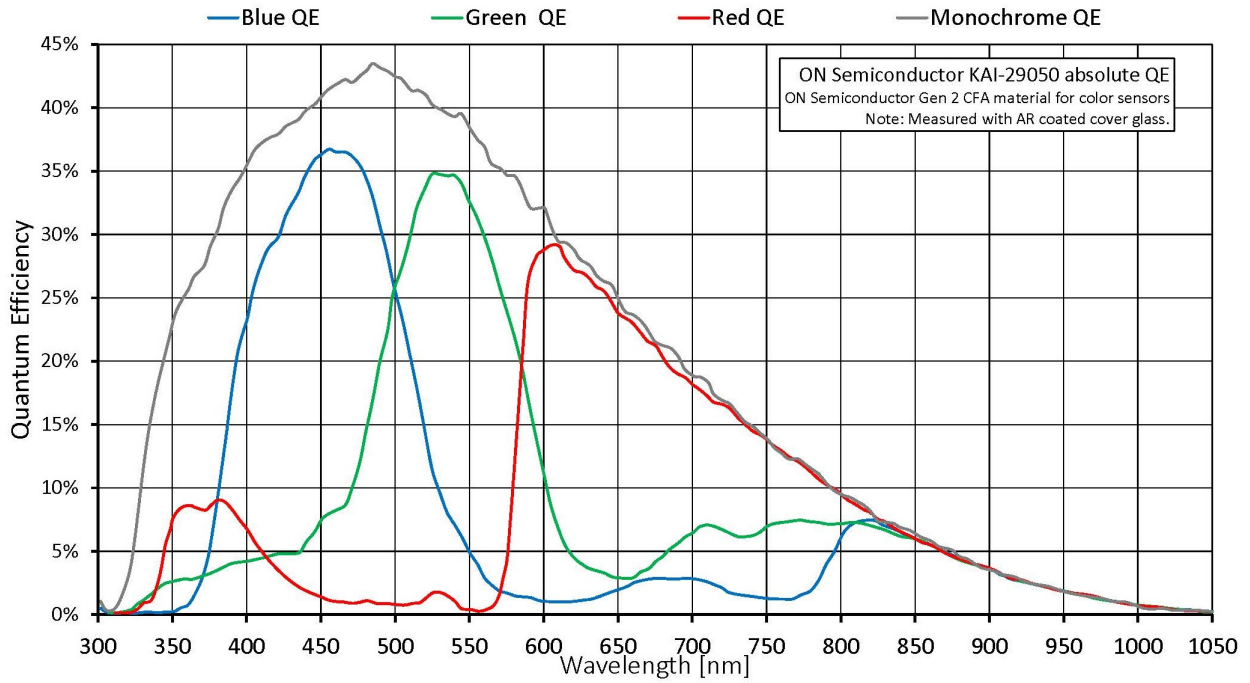

Features

Image optimization features:

- Auto gain (manual gain control: 0 to 34 dB)
- Auto exposure (manual exposure control: 30 μ s to 60 s)
- Auto white balance (GX6600C only)
- Binning (Sum)
- Region of interest (ROI), separate ROI for auto features

Camera control features:

- 3-axis motorized lens control
- Auto-Iris (video type)
- Event channel
- Global shutter (digital shutter)
- Image chunk data
- Recorder and Multiframe acquisition modes
- RS232
- Storable user sets
- StreamBytesPerSecond (bandwidth control)
- StreamHold
- Sync out modes: Trigger ready, input, exposing, readout, imaging, strobe, GPO

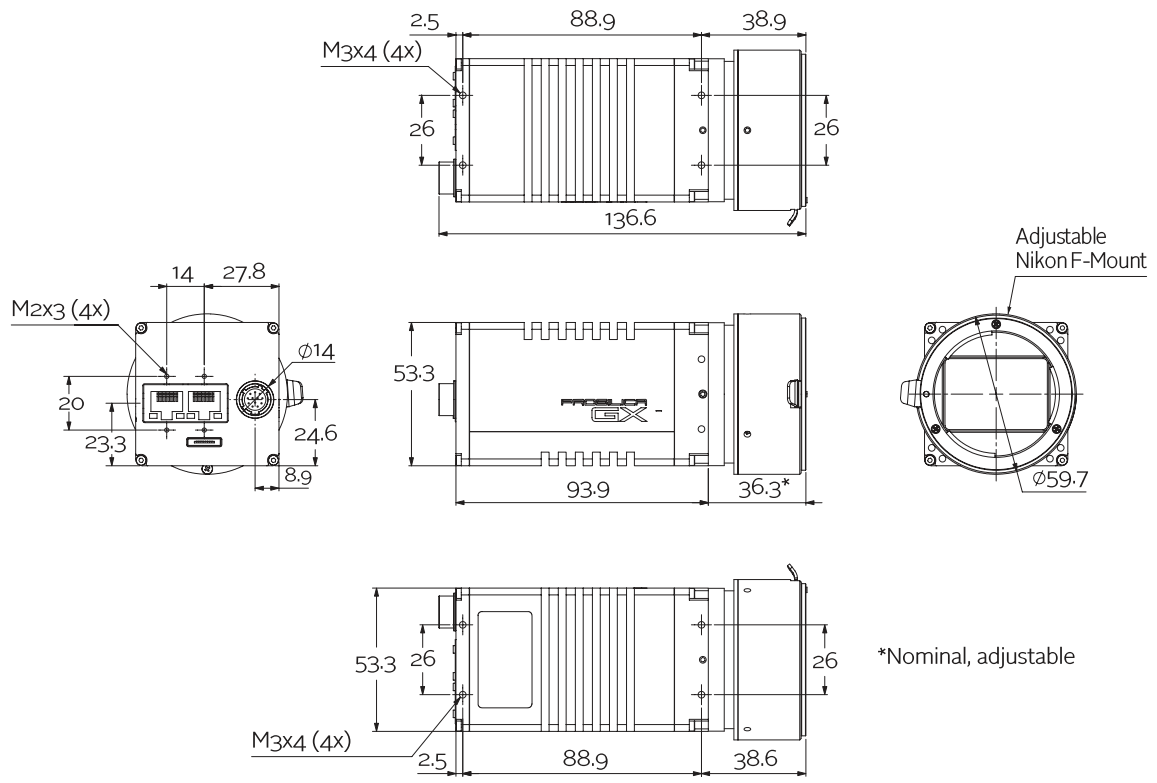

*Nominal, adjustable

Prosilica GX6600 is ideal for a wide range of applications including:

- LCD panel inspection
- High-resolution industrial inspection
- 3D metrology, general machine vision
- Public security
- Military surveillance
- Traffic imaging (Intelligent Traffic Systems)
- Embedded systems
- OEM applications
- Other machine vision applications