

Scope of this document

This document describes triggering basics for Allied Vision USB3 Vision cameras, from best-practice rules to general examples.



Features use in programming

For information on programming with features, see the *Vimba Viewer Guide*, included in **Vimba**. See: <https://www.alliedvision.com/software>.

Trigger signal flow

The following diagram shows the exposure of a frame started by an external signal. High levels show the active state of a signal. Proportions and dependencies are simplified to show the basic signal flow. Signal 1 starts Cycle 1.

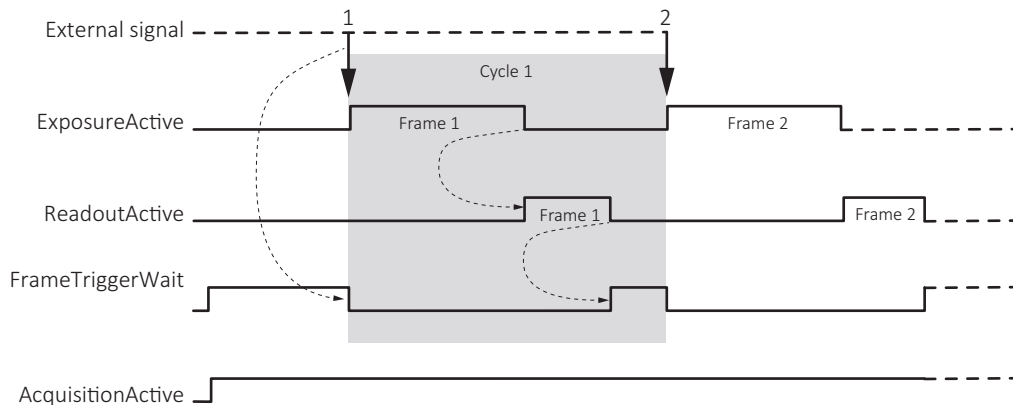

Figure 1: Trigger signal flow

Term	Description
External signal	Electrical trigger signal starting the signal flow
<i>ExposureActive</i>	Exposing a frame
<i>ReadoutActive</i>	Reading out a frame, high when the image sensor is reading out data
<i>FrameTriggerWait</i>	Waiting for a trigger
<i>AcquisitionActive</i>	<ul style="list-style-type: none"> Acquiring of frames, needs to be high to start triggering High when the camera image sensor is either exposing, reading out data, or waiting for a trigger

Table 1: Trigger signal flow, legend

Trigger latency

Trigger latency is the time delay between the *FrameStart* trigger and the start of exposure. Trigger latency consists of:

- Jitter and delay of *ExposureStart*
- *TriggerDelay*

Term	Description
<i>ExposureStart</i> jitter	<ul style="list-style-type: none"> • Deviation from the average periodical signal time • Time range mainly caused by sensor line synchronization
<i>ExposureStart</i> delay	<ul style="list-style-type: none"> • Deviation from the average periodical signal time • Time range caused by camera internal timing
<i>TriggerDelay</i>	Value set by the user to extend the trigger latency

Table 2: Trigger latency -> Components

Best practice rules for triggering

- Set the trigger to *RisingEdge* for fastest possible reaction time.
- Set the trigger pulse width in the supported range.
- Consider that the end of exposure triggers the next readout.
- Make sure the exposure of a frame ends after the readout of the previous frame.
- Start exposure only between the readouts of two lines.
- Consider that *ExposureStart* delay = readout time – *ExposureTime*.

Triggering when *ReadoutActive* is low

Apply *FrameStart* trigger when *ReadoutActive* is low. This way, you keep trigger latency (including *ExposureStart* jitter) short.

Triggering when *ReadoutActive* is high

For fastest triggering cycle time with simultaneous exposure and readout, apply *FrameStart* trigger immediately when *FrameTriggerWait* is high.

Because exposure must always begin at sensor line synchronization, the *ExposureStart* jitter can be up to 1 line cycle.



Additional information

- For detailed camera control definitions, see your camera's technical manual: <https://www.alliedvision.com/en/support/technical-documentation.html>
- For detailed camera control definitions, see *USB3 Vision Features Reference* at **Additional Documents** for your USB camera: <https://www.alliedvision.com/en/support/technical-documentation.html>

Examples

AcquisitionStart trigger and FrameStart trigger

AcquisitionStart description

To acquire images, *AcquisitionActive* must be high. Even to trigger the start of an acquisition by a pulse through an I/O, you have to issue an *AcquisitionStart* command.

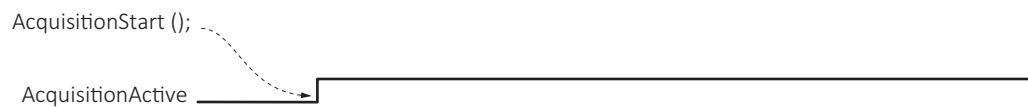

Figure 2: *TriggerMode = Off, software command: AcquisitionStart*

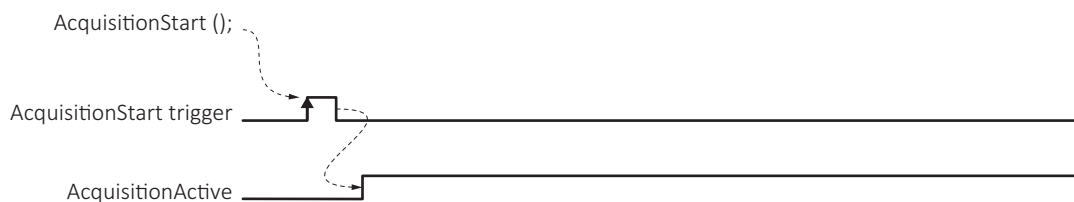

Figure 3: *TriggerMode = On, software command: AcquisitionStart*



AcquisitionStop

AcquisitionStop is mandatory to end acquisition.

With *AcquisitionMode = SingleFrame* or *MultiFrame*:

If no *AcquisitionStop* is signaled, after the selected number of frames has been acquired, the camera internally creates an *AcquisitionStop* command; this turns *AcquisitionActive* to low.

AcquisitionStart trigger and FrameStart trigger dependencies

Figure 4 shows the dependencies between `AcquisitionStart` and `FrameStart` trigger.

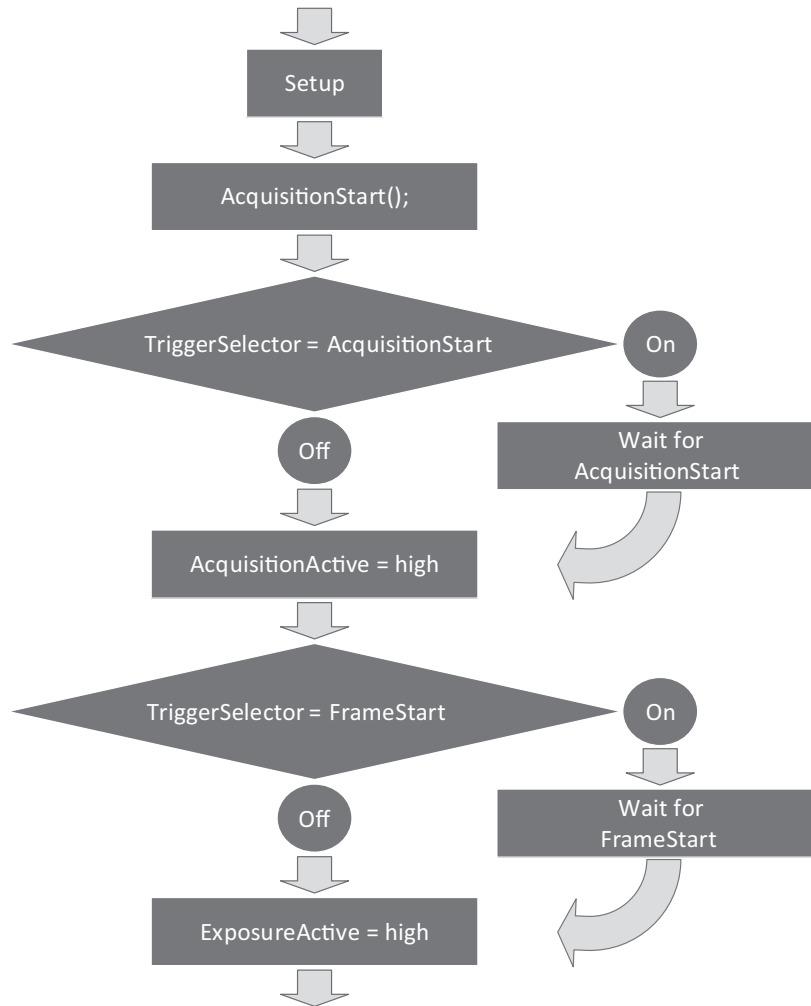

Figure 4: Dependencies of `AcquisitionStart` and `FrameStart`

Modes for triggering

The following sections describe in general the main modes for triggering:

- `TriggerMode`
- `AcquisitionMode`
- `ExposureMode`

TriggerSelector

The `TriggerSelector` examples in this section show triggering with `AcquisitionMode = Continuous`.

AcquisitionMode	TriggerSelector	
	AcquisitionStart	FrameStart
Continuous	Off	Off
Continuous	Off	On
Continuous	Off	Off
Continuous	Off	On

Table 3: *TriggerSelector* examples overview

An `AcquisitionStart` command sets `ExposureActive` to high. After this, the camera continues exposing with the maximum frame rate allowed. Maximum frame rate depends on factors, such as camera specifications and available bandwidth.

Acquisition without triggering

If no trigger is selected, the `AcquisitionStart` command starts exposure.

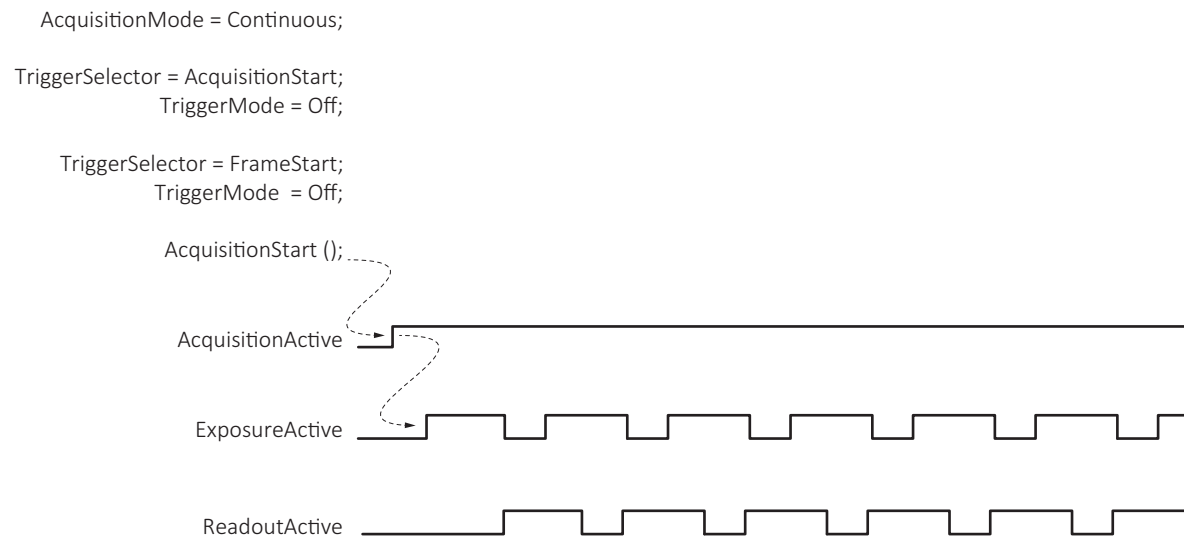

Figure 5: Acquisition without triggering

TriggerSelector = FrameStart

FrameStart triggers the exposure.

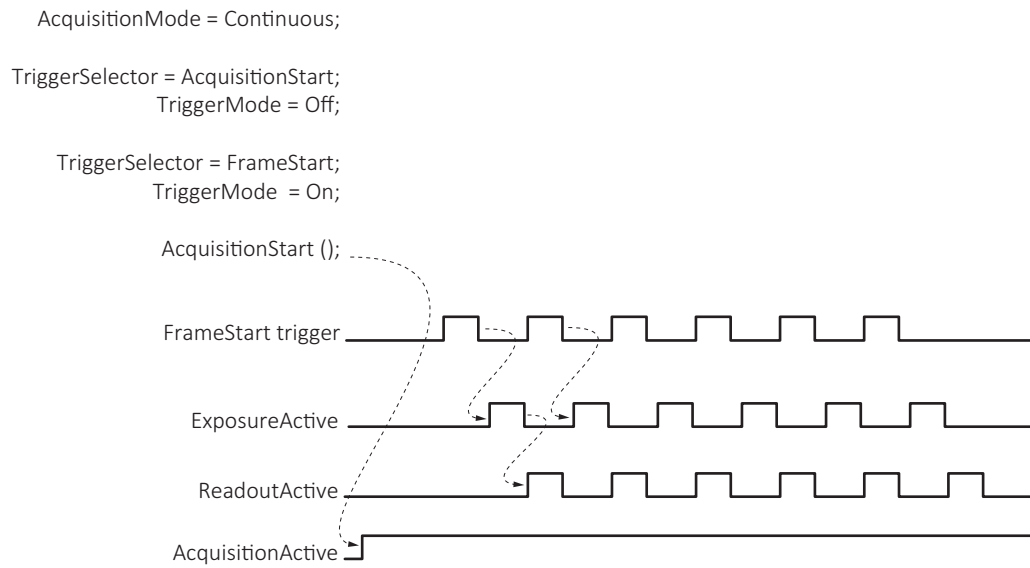

Figure 6: *TriggerSelector = FrameStart* trigger

AcquisitionMode

AcquisitionMode = SingleFrame

The `AcquisitionStart` command triggers the exposure of a single frame. Every frame needs a separate `AcquisitionStart` command.

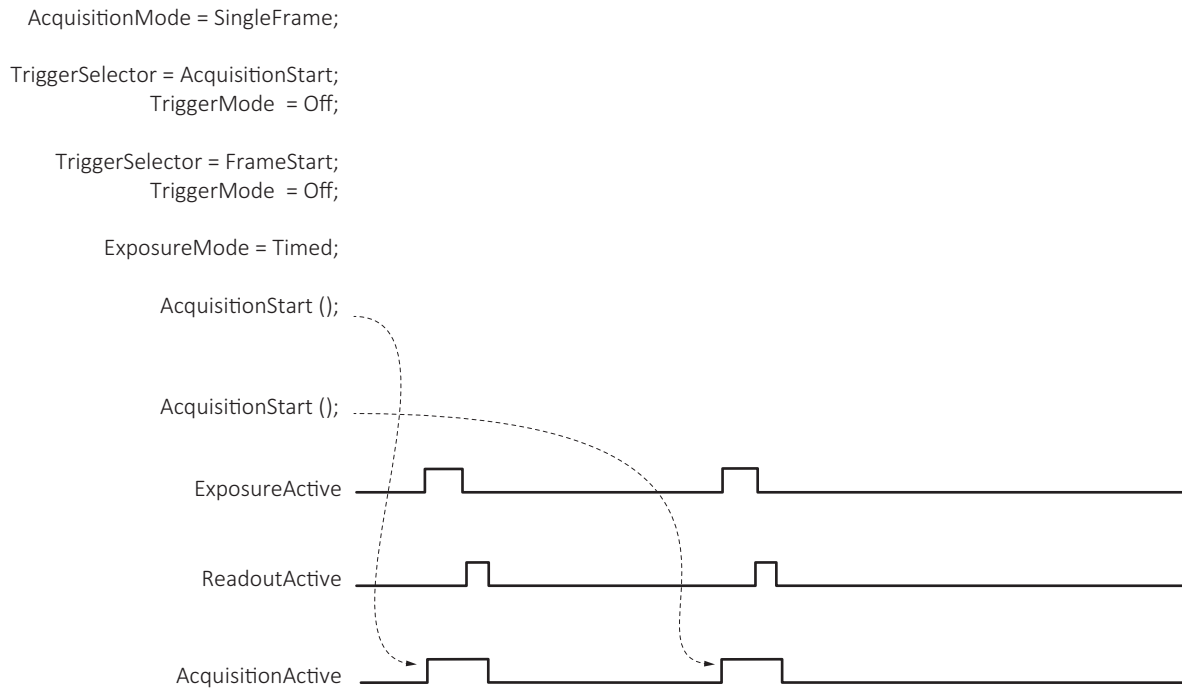

Figure 7: *AcquisitionMode = SingleFrame*

AcquisitionMode = MultiFrame

`AcquisitionStart` triggers exposure.

`FrameCount` sets the number of images.

```
AcquisitionMode = MultiFrame;  
FrameCount = 6;
```

```
TriggerSelector = AcquisitionStart;  
TriggerMode = Off;
```

```
TriggerSelector = FrameStart;  
TriggerMode = Off;
```

```
ExposureMode = Timed;
```

```
AcquisitionStart ();
```

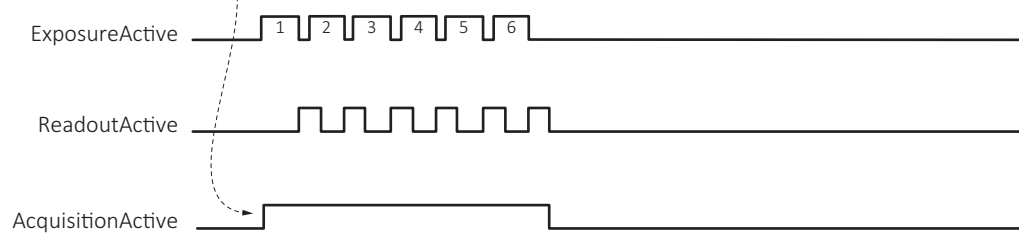

Figure 8: `AcquisitionMode = MultiFrame`

ExposureMode

ExposureMode = Timed

FrameStart triggers exposure.

ExposureTime sets exposure time.

```

AcquisitionMode = Continuous;

TriggerSelector = AcquisitionStart;
TriggerMode = Off;

TriggerSelector = FrameStart
TriggerMode = On;

ExposureMode = Timed;
ExposureTime = 500;
  
```

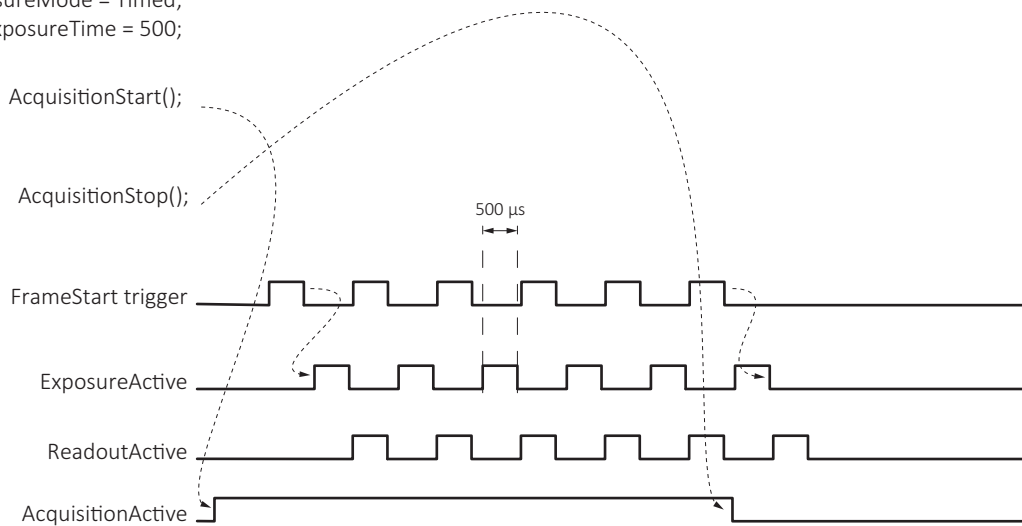

Figure 9: *ExposureMode = Timed*

ExposureMode = TriggerWidth

FrameStart triggers exposure.

The duration of the *FrameStart* trigger sets the exposure time.

```

AcquisitionMode = Continuous;

TriggerSelector = AcquisitionStart;
TriggerMode = Off;

TriggerSelector = FrameStart
TriggerMode = On;

ExposureMode = TriggerWidth;
  
```

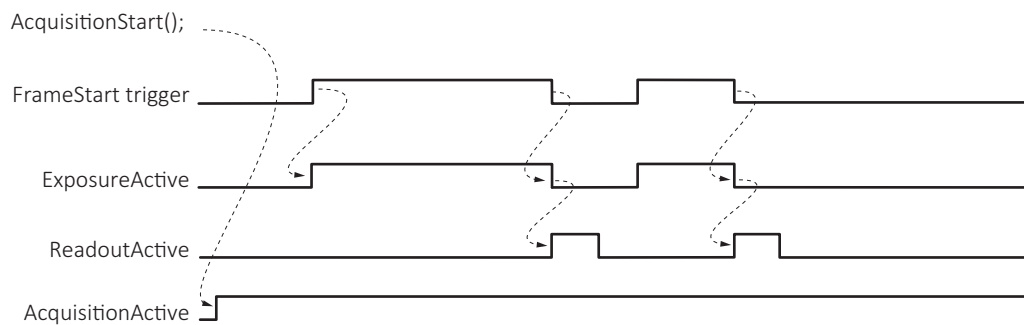

Figure 10: *ExposureMode = TriggerWidth*



ExposureModes Mako U-503B

Mako U-503B provides only *Timed* value for *ExposureMode*.



TriggerWidth and TriggerActivation

If the frame or line *TriggerActivation*[*TriggerSelector*] is *LevelHigh*, the camera exposes as long as the trigger is high.

If *TriggerActivation*[*TriggerSelector*] is *LevelLow*, the camera exposes as long as the trigger is low.

Contact

For technical support, please contact support@alliedvision.com.

For comments or suggestions regarding this document, please contact info@alliedvision.com.

Disclaimer

Due to continual product development, technical specifications may be subject to change without notice. All trademarks are acknowledged as property of their respective owners. We are convinced that this information is correct. We acknowledge that it may not be comprehensive. Nevertheless, Allied Vision cannot be held responsible for any damage in equipment or subsequent loss of data or whatsoever in consequence of this document.

Copyright © 2021 Allied Vision Technologies GmbH. All rights reserved.