

AVT Prosilica GS



Technical Manual

AVT GigE Vision Cameras

V2.0.0
70-0066

14 July 2011

Legal notice

For customers in the U.S.A.

This equipment has been tested and found to comply with the limits for a Class A digital device, pursuant to Part 15 of the FCC Rules. These limits are designed to provide reasonable protection against harmful interference when the equipment is operated in a residential environment. This equipment generates, uses, and can radiate radio frequency energy and, if not installed and used in accordance with the instruction manual, may cause harmful interference to radio communications. However there is no guarantee that interferences will not occur in a particular installation. If the equipment does cause harmful interference to radio or television reception, the user is encouraged to try to correct the interference by one or more of the following measures:

- Reorient or relocate the receiving antenna.
- Increase the distance between the equipment and the receiver.
- Use a different line outlet for the receiver.
- Consult a radio or TV technician for help.

You are cautioned that any changes or modifications not expressly approved in this manual could void your authority to operate this equipment. The shielded interface cable recommended in this manual must be used with this equipment in order to comply with the limits for a computing device pursuant to Subpart A of Part 15 of FCC Rules.

For customers in Canada

This apparatus complies with the Class A limits for radio noise emissions set out in the Radio Interference Regulations.

Pour utilisateurs au Canada

Cet appareil est conforme aux normes classe A pour bruits radioélectriques, spécifiées dans le Règlement sur le brouillage radioélectrique.

Life support applications

These products are not designed for use in life support appliances, devices, or systems where malfunction of these products can reasonably be expected to result in personal injury. Allied Vision Technologies customers using or selling these products for use in such applications do so at their own risk and agree to fully indemnify Allied for any damages resulting from such improper use or sale.

Trademarks

Unless stated otherwise, all trademarks appearing in this document of Allied Vision Technologies are brands protected by law.

Warranty

The information provided by Allied Vision Technologies is supplied without any guarantees or warranty whatsoever, be it specific or implicit. Also excluded are all implicit warranties concerning the negotiability, the suitability for specific applications or the non-breaking of laws and patents. Even if we assume that the information supplied to us is accurate, errors and inaccuracy may still occur.

Copyright

All texts, pictures and graphics are protected by copyright and other laws protecting intellectual property. It is not permitted to copy or modify them for trade use or transfer, nor may they be used on web sites.

Allied Vision Technologies Canada Inc. 7/2011

All rights reserved.

Managing Director: Mr. Frank Grube

TaxID: 889528709

Headquarters:

101-3750 North Fraser Way
V5J 5E9, Burnaby, BC / Canada

Contents

Contacting Allied Vision Technologies	5
Introduction	6
Document history	6
Symbols used in this manual.....	7
Warranty.....	7
Precautions	8
Cleaning the sensor	9
Conformity	10
Specifications	11
Prosilica GS650/650C.....	11
Prosilica GS660/660C.....	13
Prosilica GS1380/1380C	15
Prosilica GS2450/2450C	17
Camera attribute highlights.....	19
IR cut filter: spectral transmission	20
Camera dimensions	21
Mechanical drawings - Landscape sensor.....	22
Portrait sensor	23
Adjustment of lens mount	24
Camera interfaces	25
Camera I/O connector pin assignment	26
Gigabit Ethernet port	29
Camera I/O internal circuit diagram	30
Camera I/O opto-isolated user circuit example	31
Camera I/O non-isolated user circuit example	32
Video iris user circuit example.....	33
Notes on triggering	34
Timing diagram	34
Signal definitions	35

Trigger rules	36
Firmware update	37
Resolution and ROI frame rates.....	38
CAMERA: Prosilica GS650	38
CAMERA: Prosilica GS660	39
CAMERA: Prosilica GS1380	39
CAMERA: Prosilica GS2450	40
Prosilica GS family frame rate comparison	40
Additional References.....	41
Prosilica GS webpage.....	41
Prosilica GS documentation	41
GigE PvAPI SDK	41
Knowledge base	41
Case studies	41
Prosilica GS firmware.....	41

Contacting Allied Vision Technologies

Info



- **Technical information:**
<http://www.alliedvisiontec.com>
- **Support:**
support@alliedvisiontec.com

Allied Vision Technologies GmbH

Taschenweg 2a
07646 Stadtroda, Germany
Tel.: +49.36428.677-0
Fax.: +49.36428.677-28
e-mail: info@alliedvisiontec.com

Allied Vision Technologies Inc.

38 Washington Street
Newburyport, MA 01950, USA
Toll Free number +1-877-USA-1394
Tel.: +1 978-225-2030
Fax: +1 978-225-2029
e-mail: info@alliedvisiontec.com

Allied Vision Technologies Canada Inc.

101-3750 North Fraser Way
Burnaby, BC, V5J 5E9, Canada
Tel: +1 604-875-8855
Fax: +1 604-875-8856
e-mail: info@alliedvisiontec.com

Allied Vision Technologies Asia Pte. Ltd.

82 Playfair Road
#07-02 D'Lithium
Singapore 368001
Tel. +65 6634-9027
Fax:+65 6634-9029
e-mail: info@alliedvisiontec.com

Introduction

This **AVT Prosilica GS Technical Manual** describes in depth the technical specifications of this camera family including dimensions, feature overview, I/O definition, trigger timing waveforms and frame rate performance.

For information on software installation read the **AVT GigE Installation Guide**.

For detailed information on camera features and controls specific to the Prosilica GX, GE, GS, GB and GC refer to the **AVT Prosilica GigE Camera and Driver Attributes** document.

www

AVT Prosilica GS literature:



<http://www.alliedvisiontec.com/us/support/downloads/product-literature/prosilica-GS.html>

Info



Please read through this manual carefully.

Document history

Version	Date	Remarks
V2.0.0	14.07.11	New Manual – SERIAL Status

Table 1: Document History

Symbols used in this manual

Note This symbol highlights important information



Caution This symbol highlights important instructions. You must follow these instructions to avoid malfunctions.



www This symbol highlights URLs for further information. The URL itself is shown in blue.



Example:

<http://www.alliedvisiontec.com>

Warranty

Info Allied Vision Technologies Canada provides a 2-year warranty which covers the replacement and repair of all AVT parts that are found to be defective in the normal use of this product. AVT will not warranty parts that have been damaged through the obvious misuse of this product.



Precautions

Caution



DO NOT OPEN THE CAMERA. WARRANTY IS VOID IF CAMERA IS OPENED.

This camera contains sensitive components which can be damaged if handled incorrectly.

Caution



KEEP SHIPPING MATERIAL.

Poor packaging of this product can cause damage during shipping.

Caution



VERIFY ALL EXTERNAL CONNECTIONS.

Verify all external connections in terms of voltage levels, power requirements, voltage polarity, and signal integrity prior to powering this device.

Caution



CLEANING.

This product can be damaged by some volatile cleaning agents. Avoid cleaning the image sensor unless absolutely necessary. Please see instructions on sensor cleaning in this document.

Caution



DO NOT EXCEED ENVIRONMENTAL SPECIFICATIONS.

See environmental specifications limits in the Specifications section of this document. Special care is required to maintain a reasonable operating temperature. If the camera is to be operated in a warm environment, it is suggested that the camera be mounted on a heat sink such as a metal bracket and that there is sufficient air flow.

Cleaning the sensor

Caution



DO NOT CONTACT CLEAN SENSOR UNLESS ABSOLUTELY NECESSARY

Identifying Debris

Debris on the image sensor or optical components will appear as a darkened area or smudge on the image that does not move as the camera is moved. Do not confuse this with a pixel defect which will appear as a distinct point.

Locating Debris

Before attempting to clean the image sensor, it is important to first determine that the problem is due to debris on the sensor window. To do this you, should be viewing a uniform image, such as a piece of paper, with the camera. Debris will appear as a dark spot or dark region that does not move as the camera is moved. To determine that the debris is not on the camera lens, rotate the lens independent of the camera. If the spot moves as the lens moves, then the object is on the lens not on the image sensor and therefore cleaning is not required. If the camera has an IR filter, then rotate the IR filter. If the object moves, then the particle is on the IR filter not the sensor. If this is the case, remove the IR filter carefully using a small flat head screw driver. Clean both sides of the IR filter using the same techniques as explained below for the sensor window.

Caution



DO NOT TOUCH ANY OPTICS WITH FINGERS. OIL FROM FINGERS CAN DAMAGE FRAGILE OPTICAL COATINGS.

Cleaning with Air

If it is determined that debris is on the sensor window, then remove the camera lens, and blow the sensor window directly with clean compressed air. If canned air is used, do not shake or tilt the can prior to blowing the sensor. View a live image with the camera after blowing. If the debris is still there, repeat this process. Repeat the process a number of times with increased intensity until it is determined that the particulate cannot be dislodged. If this is the case then proceed to the contact cleaning technique.

Contact Cleaning

Only use this method as a last resort. Use 99% laboratory quality isopropyl alcohol and clean cotton swabs. Dampen the swab in the alcohol and gently wipe the sensor in a single stroke. Do not reuse the same swab. Do not wipe the sensor if the sensor and swab are both dry. You must wipe the sensor quickly after immersion in the alcohol, or glue from the swab will contaminate the sensor window. Repeat this process until the debris is gone. If this process fails to remove the debris, then contact AVT.

Conformity

Allied Vision Technologies declares under its sole responsibility that all standard cameras of the **AVT Prosilica GS** family to which this declaration relates are in conformity with the following standard(s) or other normative document(s):

- CE, following the provisions of 2004/108/EG directive
- FCC Part 15 Class A
- RoHS (2002/95/EC)



We declare, under our sole responsibility, that the previously described **AVT Prosilica GS** cameras conform to the directives of the CE.



Note: This equipment has been tested and found to comply with the limits for a Class A digital device, pursuant to part 15 of the FCC Rules. These limits are designed to provide reasonable protection against harmful interference in a residential environment. This equipment generates, uses, and can radiate radio frequency energy and, if not installed and used in accordance with the instructions, may cause harmful interference to radio communications. Operation of this equipment in a residential area is likely to cause harmful interference in which case the user will be required to correct the interference at his own expense. You are cautioned that any changes or modifications not expressly approved in this manual could void your authority to operate this equipment.

Specifications

Prosilica GS	650/650C
Resolution	659 x 493
Sensor	Sony ICX424
Type	CCD Progressive
Sensor size	Type 1/3
Cell size	7.4 μm
Lens mount	C/CS
Max frame rate at full resolution	120 fps
A/D	14 bit
On-board FIFO	16 MB
Bit depth	8/12
Mono formats	Mono8, Mono16 (monochrome models only)
Color formats	Bayer8, Bayer16, YUV411, YUV422, YUV444, RGS24, BGR24, RGSA24, BGRA24
Exposure control	10 μs to 60 seconds; 1 μs increments
Gain control	0 to 30 dB
Horizontal binning	0 to 8 pixels
Vertical binning	1 to 14 rows
TTL I/Os	1 input, 1 output
Opto-coupled I/Os	1 input, 1 output
RS-232	1
Power requirements	5-16 VDC \rightarrow Cameras SN: 02-22XXA 5-25 VDC \rightarrow Cameras SN: 02-22XXB
Power consumption	3W
Mass	59g (without lens)
Dimensions	51 x 89 mm (Board Size - W x L)
Sensor orientations	Landscape, Portrait
Operating temperature	0 $^{\circ}\text{C}$... +70 $^{\circ}\text{C}$ ambient temperature (without condensation)
Connector orientations	Inline, Vertical
Storage temperature	-10 $^{\circ}\text{C}$... +70 $^{\circ}\text{C}$ ambient temperature (without condensation)
Trigger latency	1 μs for non-isolated I/O, 9 μs for isolated I/O
Trigger jitter	\pm 20ns for non-isolated I/O, \pm 0.5 μs for isolated I/O
Tpd	10ns for non-isolated I/O, 1.3 μs for isolated I/O
Operating humidity	20 to 80% non-condensing
Hardware interface standard	IEEE 802.3 1000BASE-T, 100BASE-TX
Software interface standard	GigE Vision Standard 1.0
Regulatory	CE, FCC Class A, RoHS (2002/95/EC)

Table 2: Prosilica GS650 camera specification

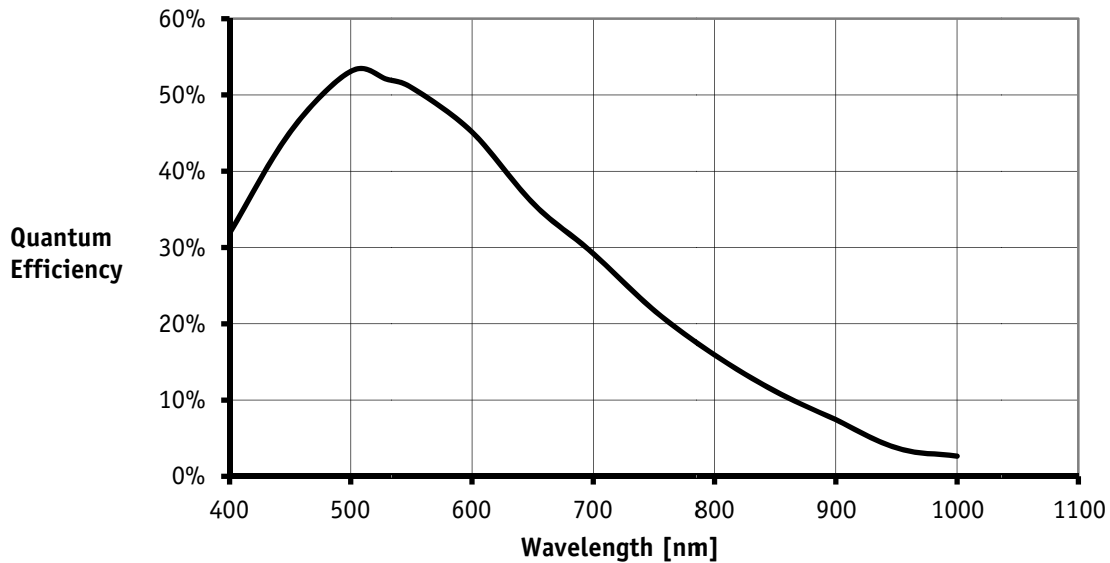

Figure 1 – Prosilica GS650 monochrome spectral response

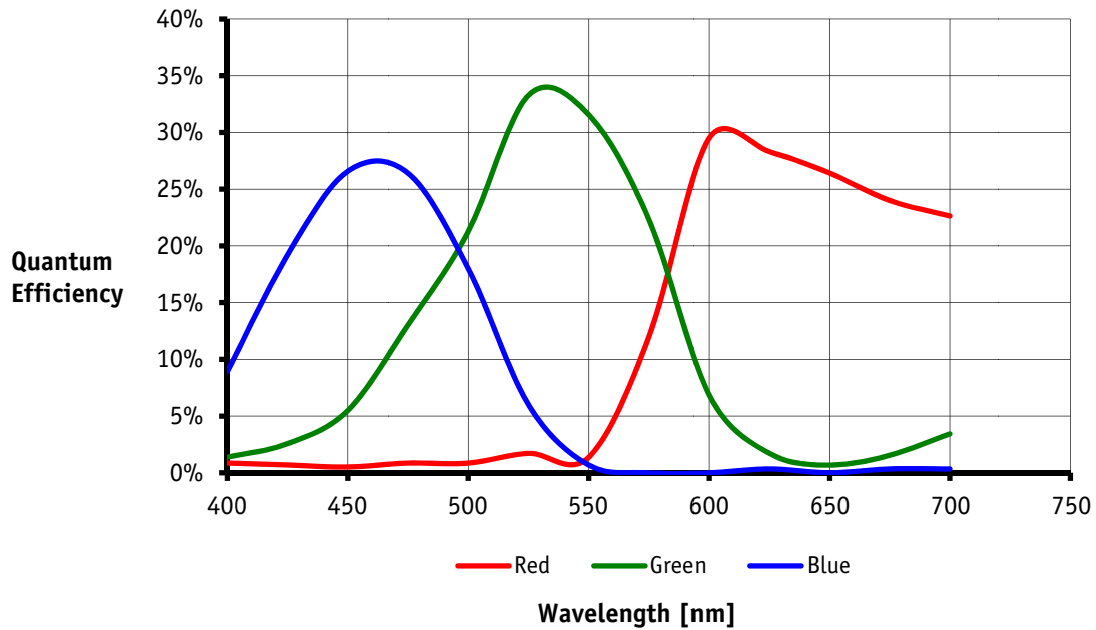

Figure 2 – Prosilica GS650C color spectral response

Note — The design and specifications for the products described above may change without notice.



Specifications

Prosilica GS	660/660C
Resolution	659 x 493
Sensor	Sony ICX618
Type	CCD Progressive
Sensor size	Type ¼
Cell size	5.6 µm
Lens mount	C/CS
Max frame rate at full resolution	119 fps
A/D	14 bit
On-board FIFO	16 MB
Bit depth	8/12
Mono formats	Mono8, Mono16 (monochrome models only)
Color formats	Bayer8, Bayer16, YUV411, YUV422, YUV444, RGS24, BGR24, RGSA24, BGRA24
Exposure control	10 µs to 60 seconds; 1 µs increments
Gain control	0 to 30 dB
Horizontal binning	0 to 8 pixels
Vertical binning	1 to 16 rows
TTL I/Os	1 input, 1 output
Opto-coupled I/Os	1 input, 1 output
RS-232	1
Power requirements	5-16 VDC → Cameras SN: 02-22XXA 5-25 VDC → Cameras SN: 02-22XXB
Power consumption	3W
Mass	59g (without lens)
Dimensions	51 x 89 mm (Board Size - W x L)
Sensor orientations	Landscape
Operating temperature	0 °C ... +70 °C ambient temperature (without condensation)
Storage temperature	-10 °C ... +70 °C ambient temperature (without condensation)
Trigger latency	2 µs for non-isolated I/O, 10µs for isolated I/O
Trigger jitter	±20ns for non-isolated I/O, ±0.5µs for isolated I/O
Tpd	10ns for non-isolated I/O, 1.3µs for isolated I/O
Operating humidity	20 to 80% non-condensing
Hardware interface standard	IEEE 802.3 1000BASE-T, 100BASE-TX
Software interface standard	GigE Vision Standard 1.0
Regulatory	CE, FCC Class A, RoHS (2002/95/EC)

Table 3: Prosilica GS660 camera specification

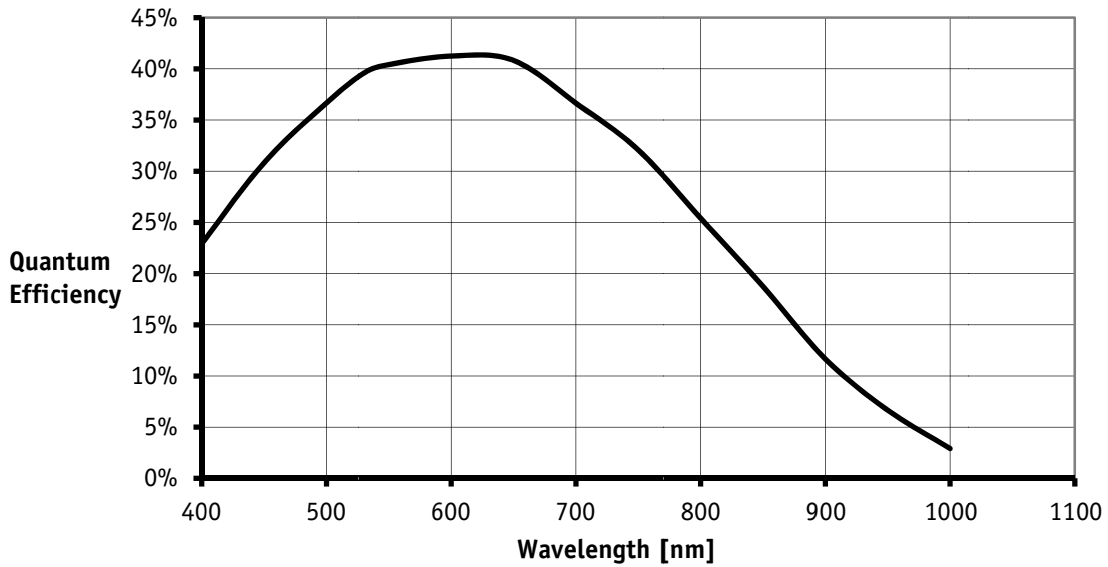

Figure 3 – Prosilica GS660 monochrome spectral response

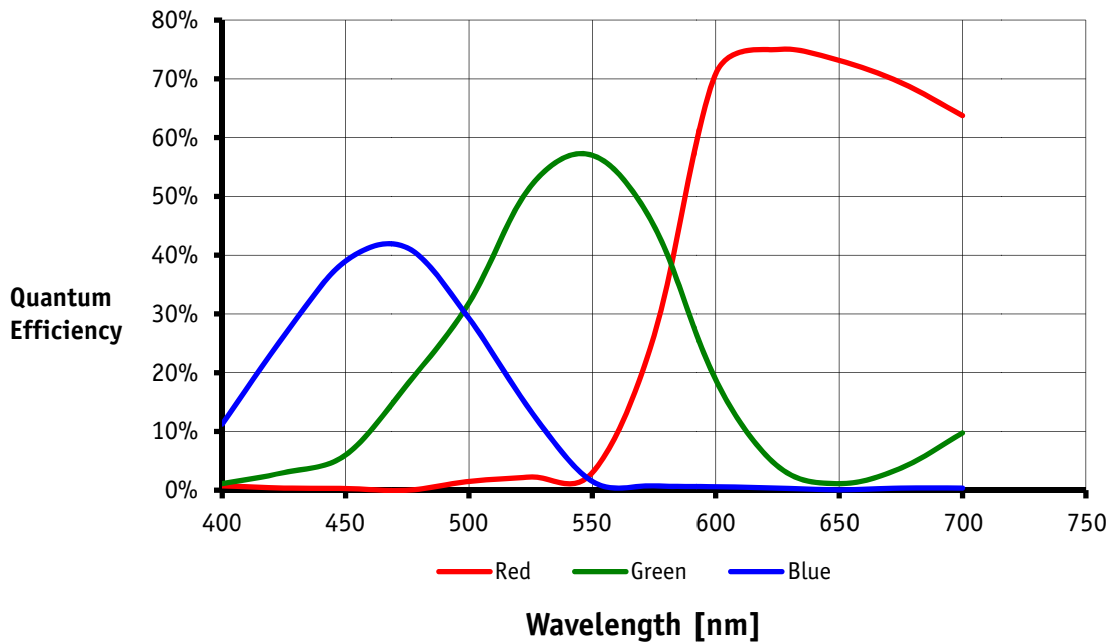

Figure 4 – Prosilica GS660C color spectral response

Note — The design and specifications for the products described above may change without notice.



Specifications

Prosilica GS	1380/1380C
Resolution	1360 x 1024 pixels
Sensor	Sony ICX285AL CCD (ICX285AQ for color)
Type	CCD Progressive
Sensor size	Type 2/3
Cell size	6.45µm
Lens mount	C/CS
Max frame rate at full resolution	30 fps
A/D	14 bit
On-board FIFO	16 MB
Bit depth	8/12
Mono formats	Mono8, Mono16 (monochrome models only)
Color formats	Bayer8, Bayer16, YUV411, YUV422, YUV444, RGS24, BGR24, RGSA24, BGRA24
Exposure control	10 µs to 60 seconds; 1 µs increments
Gain control	0 to 30 dB
Horizontal binning	1 to 8 pixels
Vertical binning	1 to 14 rows
TTL I/Os	1 input, 1 output
Opto-coupled I/Os	1 input, 1 output
RS-232	1
Power requirements	5-16 VDC → Cameras SN: 02-22XXA 5-25 VDC → Cameras SN: 02-22XXB
Power consumption	3W
Mass	54g
Dimensions	51 x 89 (board size - W x L)
Sensor orientations	Landscape, Portrait
Operating temperature	0 °C ... +70 °C ambient temperature (without condensation)
Storage temperature	-10 °C ... +70 °C ambient temperature (without condensation)
Trigger latency	1µs for non-isolated I/O, 9µs for isolated I/O
Trigger jitter	±20ns for non-isolated I/O, ±0.5µs for isolated I/O
Tpd	10ns for non-isolated I/O, 1.3µs for isolated I/O
Operating humidity	20 to 80% non-condensing
Hardware interface standard	IEEE 802.3 1000BASE-T, 100BASE-TX
Software interface standard	GigE Vision Standard 1.0
Regulatory	CE, FCC Class A, RoHS (2002/95/EC)

Table 4: Prosilica GS1380 camera specification

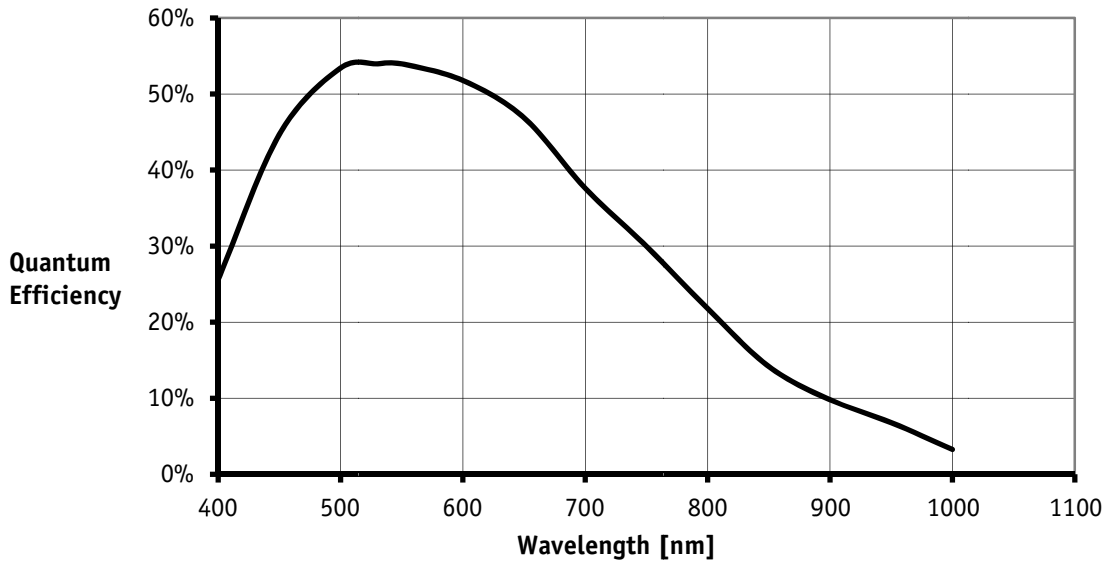

Figure 5 – Prosilica GS1380 monochrome spectral response

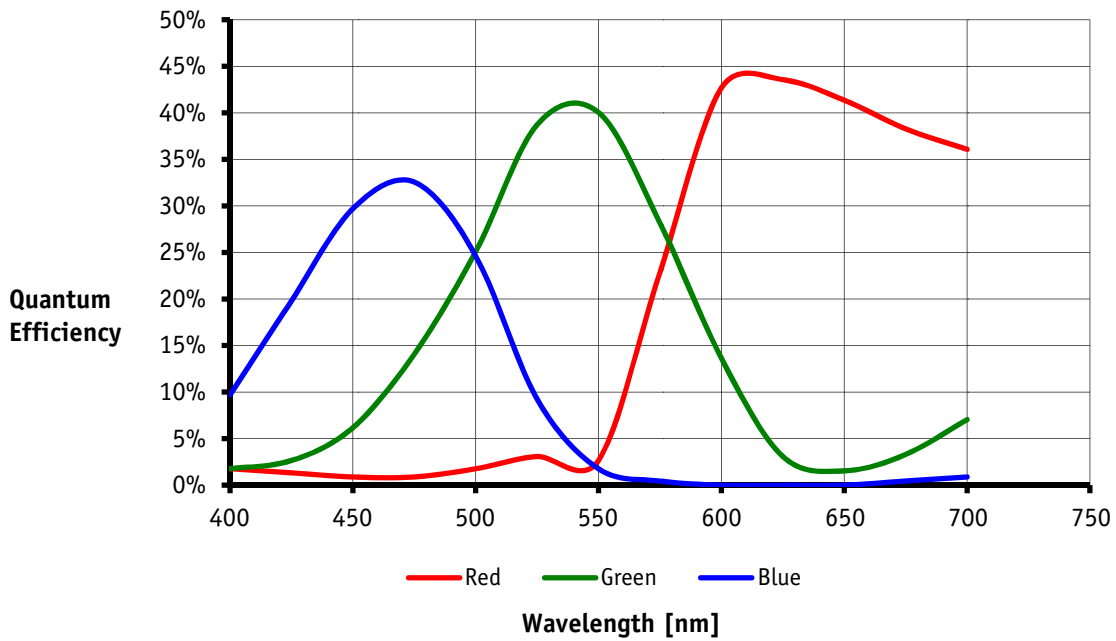

Figure 6 – Prosilica GS1380C color spectral response

Note



The design and specifications for the products described above may change without notice.

Specifications

Prosilica GS	2450/2450C
Resolution	2448 x 2050
Sensor	Sony ICX625
Type	CCD Progressive
Sensor size	Type 2/3
Cell size	3.45 μm
Lens mount	C/CS
Max frame rate at full resolution	15 fps
A/D	14 bit
On-board FIFO	16 MB
Bit depth	8/12
Mono formats	Mono8, Mono16 (monochrome models only)
Color formats	Bayer8, Bayer16, YUV411, YUV422, YUV444, RGS24, BGR24, RGSA24, BGRA24
Exposure control	10 μs to 60 seconds; 1 μs increments
Gain control	0 to 30 dB
Horizontal binning	1 to 8 pixels
Vertical binning	1 to 14 rows
TTL I/Os	1 input, 1 output
Opto-coupled I/Os	1 input, 1 output
RS-232	1
Power requirements	5-16 VDC \rightarrow Cameras SN: 02-22XXA 5-25 VDC \rightarrow Cameras SN: 02-22XXB
Power consumption	3W
Mass	54g
Dimensions	51 x 89 (board size - W x L)
Sensor orientations	Landscape, Portrait
Operating temperature	0 $^{\circ}\text{C}$... +70 $^{\circ}\text{C}$ ambient temperature (without condensation)
Storage temperature	-10 $^{\circ}\text{C}$... +70 $^{\circ}\text{C}$ ambient temperature (without condensation)
Trigger latency	2 μs for non-isolated I/O, 10 μs for isolated I/O
Trigger jitter	$\pm 20\text{ns}$ for non-isolated I/O, $\pm 0.5\mu\text{s}$ for isolated I/O
Tpd	10ns for non-isolated I/O, 1.3 μs for isolated I/O
Operating humidity	20 to 80% non-condensing
Hardware interface standard	IEEE 802.3 1000BASE-T, 100BASE-TX
Software interface standard	GigE Vision Standard 1.0
Regulatory	CE, FCC Class A, RoHS (2002/95/EC)

Table 5: Prosilica GS2450 camera specification

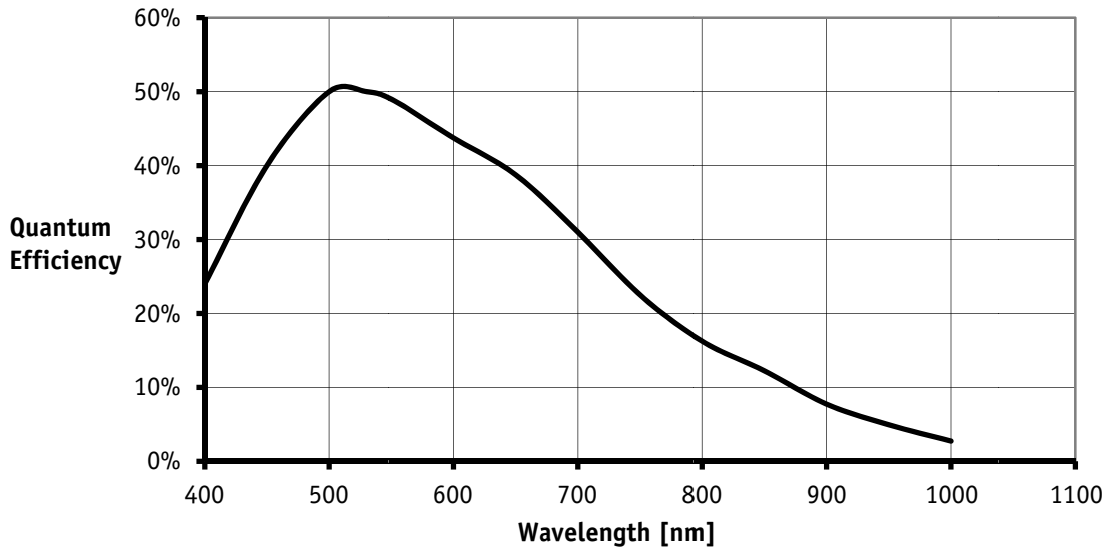

Figure 7 – Prosilica GS2450 monochrome spectral response

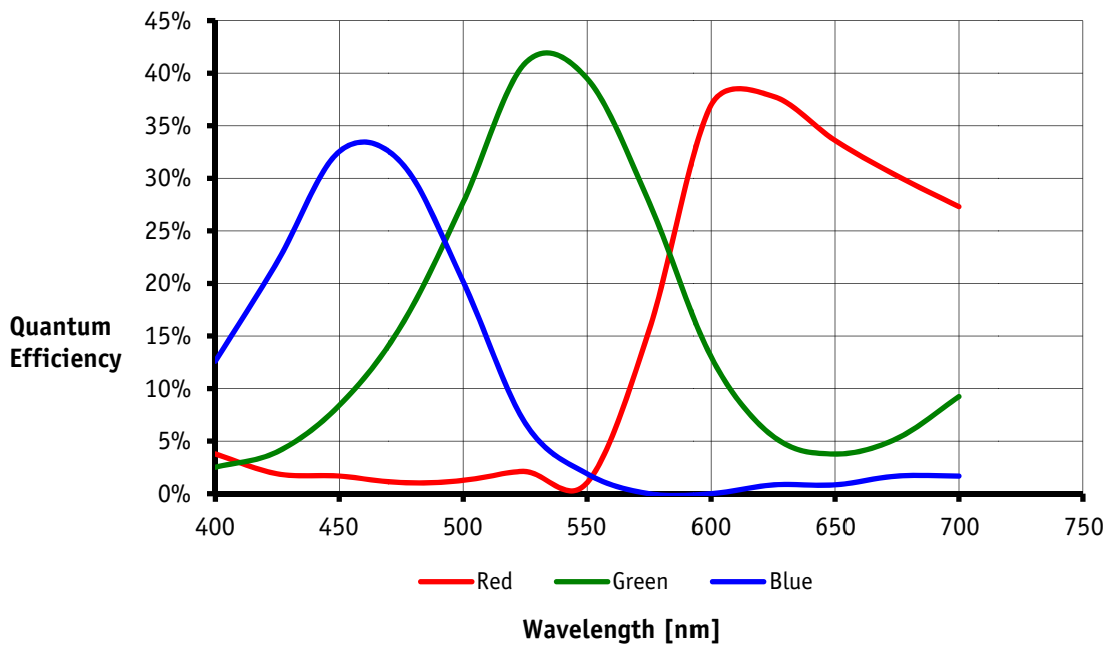

Figure 8 – Prosilica GS2450C color spectral response

Note



The design and specifications for the products described above may change without notice.

Camera attribute highlights

AVT cameras support a number of standard and extended features. The table below identifies the most interesting capabilities of this camera family. A complete listing of camera controls, including control definitions can be found in the **AVT Prosilica GigE Camera and Driver Attributes** document.

www



AVT Prosilica GigE Camera and Driver Attributes document online:

http://www.alliedvisiontec.com/fileadmin/content/PDF/Software/Prosilica_software/Prosilica_firmware/AVT_Camera_and_Driver_Attributes.pdf

Control	Specification
Gain control	Manual and auto
Exposure control	Manual and auto
Whitebalance	Red and blue channel; manual and auto control
External trigger event	Rising edge, falling edge, any edge, level high, level low
External trigger delay	0 to 60 seconds; 1 us increments
Fixed rate control	0.001 fps to maximum frame rate
Imaging modes	Free-running, external trigger, fixed rate, software trigger
Sync Out modes	Trigger ready, trigger input, exposing, readout, imaging, strobe, GPO
Region of Interest (ROI)	independent x and y control with 1 pixel resolution
Multicast	Streaming to multiple PC
Event Channel	In-camera events including exposure start and trigger are asynchronously broadcasted to the host PC

Table 6: Prosilica GS camera and driver attribute highlights

IR cut filter: spectral transmission

Note



All **Prosilica GS** color models are equipped with an infrared block filter (IR filter). This filter is employed to stop infrared wavelength photons from passing to the imaging device. If the filter is removed, images will be dominated by red and cannot be properly color balanced.

Monochrome **Prosilica GS** cameras do not employ an IR filter.

The figure below shows the filter transmission response for the IRC filter family from Sunex. Prosilica GS cameras utilize the IRC30 filter.

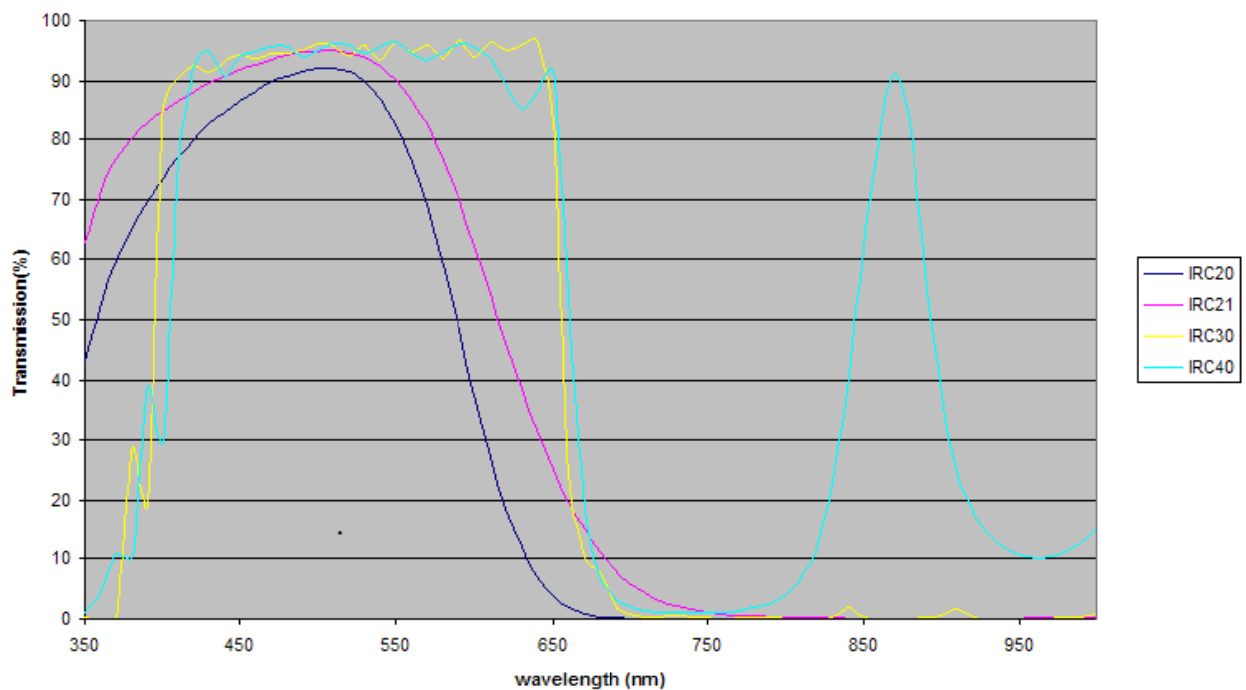

Figure 9: Sunex IRC filter transmission values

Camera dimensions

The **Prosilica GS** camera offers several sensor orientation options. The camera variations are described below and detailed dimension drawings are provided in Chapter **Mechanical drawings** on page 22.

Sensor orientation	Model	Description	Example
Landscape	GS	Sensor mounted in landscape orientation	GS1380
Portrait	GS-P	Sensor mounted in portrait orientation	GS1380-P

Table 7: GS Sensor orientations

Landscape Orientation
(i.e. GS1380)



Portrait Orientation
(i.e. GS1380-P)

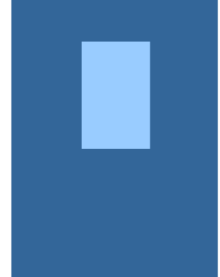

Note



Some models do not support a portrait sensor orientation, please refer to Chapter **Specifications** on page 11.

Mechanical drawings - Landscape sensor

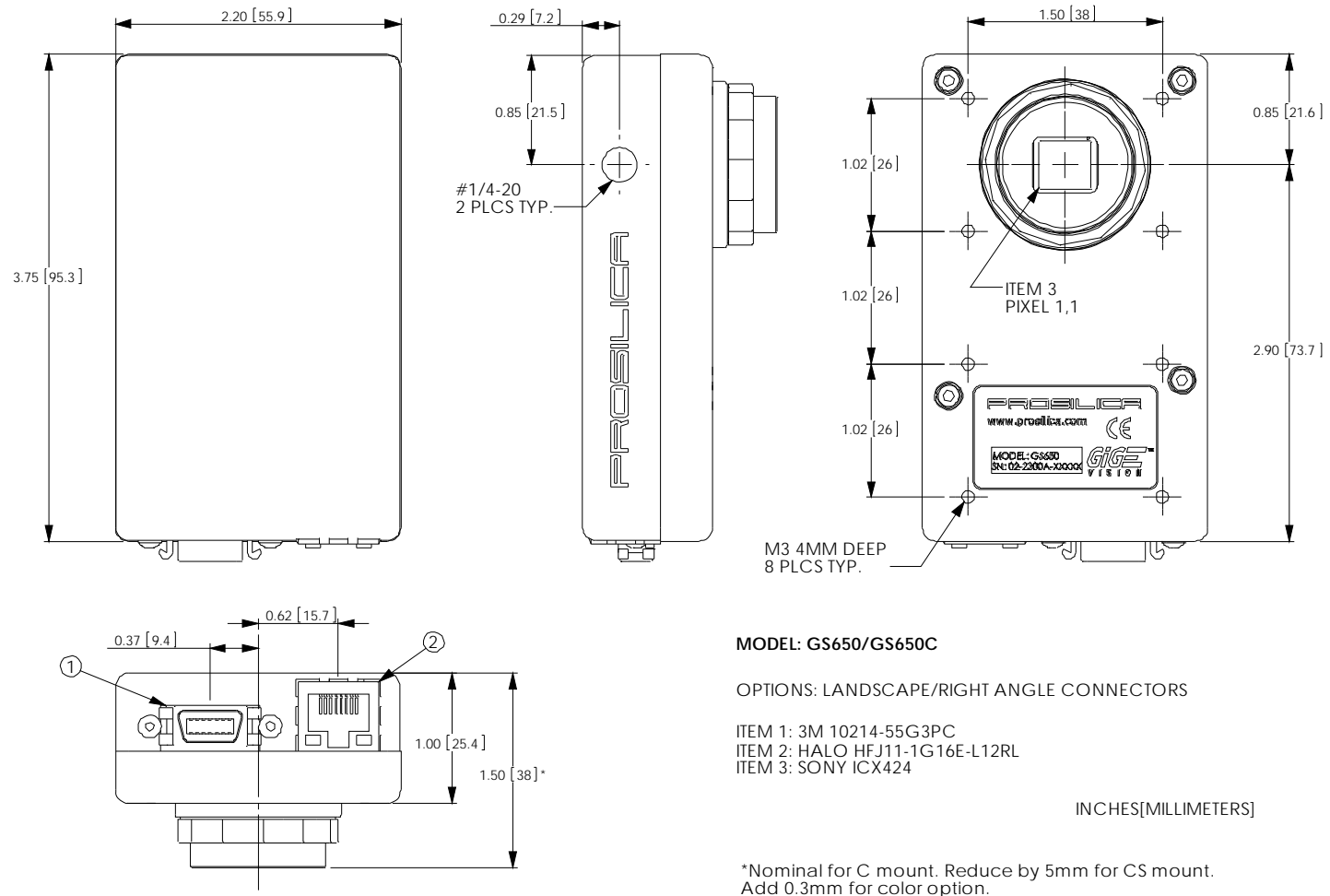

Figure 10: Prosilica GS650/GS650C mechanical drawing

Portrait sensor

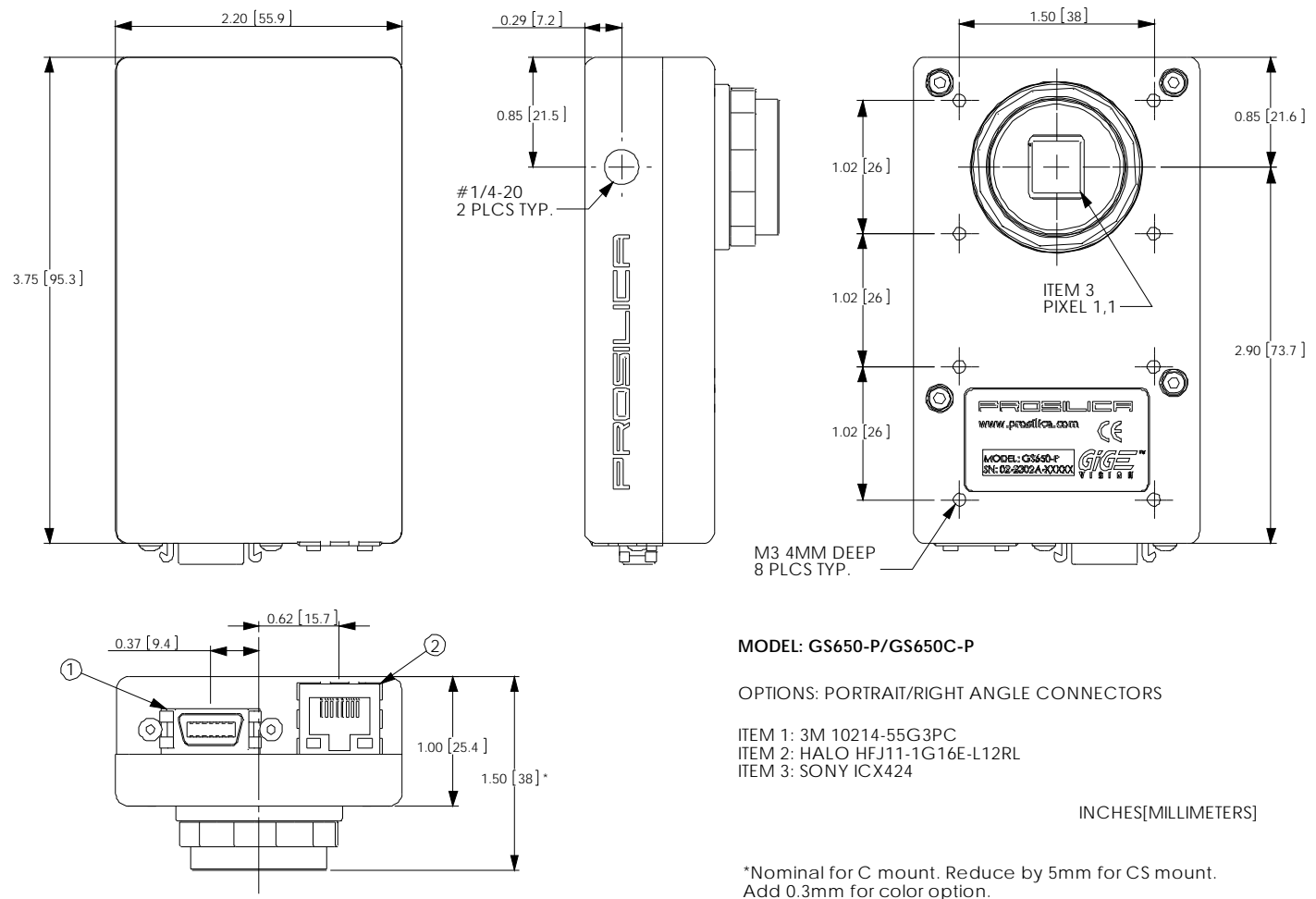

Figure 11: Prosilica GS650-P/GS650C-P mechanical drawing

Adjustment of lens mount

Caution



The C-mount or CS-mount is adjusted at the factory and should not require adjusting. If for some reason, the lens mount requires adjustment, use the following method.

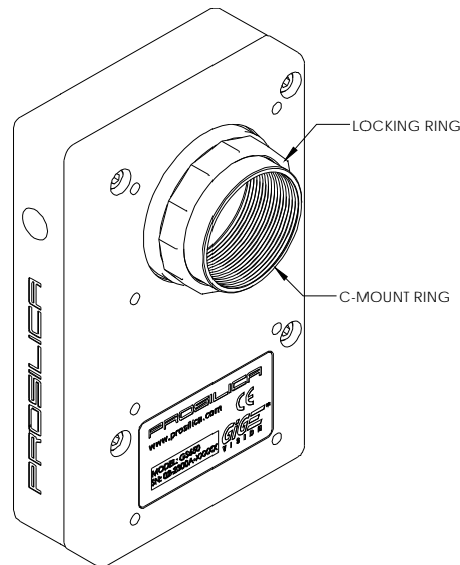

Figure 12: Prosilica GS camera front view

Loosen Locking Ring

Use an adjustable wrench to loosen locking ring. Be careful not to scratch the camera. When the locking ring is loose, unthread the ring a few turns from the camera face.

Note

A wrench suitable for this procedure can be provided by AVT
P/N: 02-5003A



Prosilica GS cameras can be equipped with a C-mount or a CS-mount depending on sensor size and camera order code

Image to Infinity

Use a c-mount compatible lens that allows an infinity focus. Set the lens to infinity and image a distant object. The distance required will depend on the lens used but typically 30 to 50 feet should suffice. Make sure the lens is firmly threaded onto the c-mount ring. Rotate the lens and c-mount ring until the image is focused. Carefully tighten locking ring. Recheck focus.

Camera interfaces

This chapter gives you information on Gigabit Ethernet port, inputs and outputs and trigger features.

www



For accessories like cables see:

<http://www.alliedvisiontec.com/emea/products/accessories/gige-accessories.html>

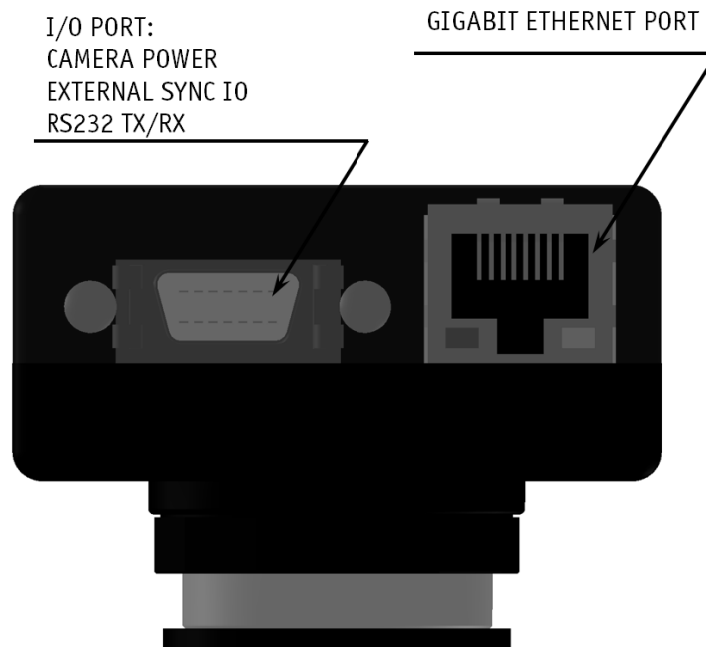
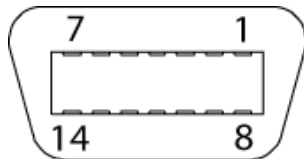

Figure 13: Prosilica GS connection diagram

Camera I/O connector pin assignment



Pin	Signal	Direction	Level	Description
1	External Power	---	+5 V...+12 V DC (see note)	Power Supply
2	External GND	---	GND for power	External Ground for external power
3	Camera In 1	In	$U_{in}(\text{high}) = 5 \text{ V} \dots 24 \text{ V}$ $U_{in}(\text{low}) = 0 \text{ V} \dots 0.8 \text{ V}$	Camera Input 1 opto-isolated (GPIn1)
4	Isolated GND	---	---	Ground for isolated outputs (Isolated GND)
5	Camera Out1	Out	Open emitter max. 20mA	Camera Output 1 opto-isolated (GPOut1)
6	Video Iris	Out	---	PWM Signal for Iris Control
7	Reserved	---	---	---
8	External Power	---	+5 V...+16 V DC (see note)	Power Supply
9	External GND	---	GND for ext. power	External Ground for external power
10	TxD RS232	Out	RS232	Terminal Transmit Data
11	RxD RS232	In	RS232	Terminal Receive Data
12	Camera In 2	In	LVTTTL max. 3.3 V	Camera Input 2 non-isolated (GPIn2)
13	Camera Out 2	Out	LVTTTL max. 3.3 V	Camera Output 2 non-isolated (GPOut2)
14	Non-isolated GND	---	---	Ground for non-isolated outputs and RS232

Table 8: Prosilica GS I/O connector definition

The General Purpose I/O port uses a 3M 10214-55G3PC (or 3M 10214-6212PC) connector on the camera side. The mating cable connector is 3M 10114-3000PE or a connector with shielded housing 3M 10314-3210-00X (X indicates color preference).

Note This cable side Hirose connector can be purchased from AVT.
AVT P/N: 02-7003A



External Power

The Prosilica GS camera family has recently been updated to offer an expanded input power voltage range. The camera serial number is used to differentiate between cameras that offer 5-16 VDC and those that offer 5-25 VDC.

Caution



SN: 02-22XXA, 5V - 16V. 12V Nominal.
SN: 02-22XXB, 5V - 25V. 12V Nominal.

Note



A 12V power adaptor with camera connector can be ordered from AVT:
AVT P/N: 02-8007A North America Supply
AVT P/N: 02-8008A Universal Supply

Camera In 1 and Camera In 2

These are trigger lines which allow the camera to be synchronized to an external event. The camera can be programmed to trigger on the rising edge, falling edge, both edges, or level of this signal. The camera can also be programmed to capture an image at some programmable delay time after the trigger event.

GPIIn1 is isolated and should be used in noisy environments to prevent false triggering due to ground loop noise. GPIIn2 is non-isolated and can be used when a faster trigger is required and when environmental noise is not a problem.

Caution



DO NOT EXCEED 5.5V ON SIGNAL INPUTS UNLESS OTHERWISE INDICATED

Please refer to Chapter **Camera I/O opto-isolated user circuit example** on page 31.

Camera Out 1 and Camera Out 2

These signals (GPOut) only function as outputs and can be configured as follows:

Exposing	Corresponds to when camera is integrating light.
Trigger Ready	Indicates when the camera will accept a trigger signal.
Trigger Input	A relay of the trigger input signal used to “daisy chain” the trigger signal for multiple cameras.
Readout	Valid when camera is reading out data.
Imaging	Valid when camera is exposing or reading out.
Strobe	Programmable pulse based on one of the above events.
GPO	User programmable binary output.

Any of the above signals can be set for active high or active low.

GPOut 1 is isolated and should be used in noisy environments. GPOut2 is non-isolated and can be used when environmental noise is not a problem and when faster response is required.

GPOut1 will require a pull up resistor of greater than 1Kohm to the user’s 5V logic supply. Review circuit diagrams for more information.

RxD RS-232 and TxD RS-232

These signals are RS-232 compatible. These signals allow communication from the host system via the Ethernet port to a peripheral device connected to the camera. Note that these signals are not isolated and therefore careful attention should be used when designing cabling in noisy environments.

Isolated Ground

The isolated ground must be connected to the user’s external circuit ground if GPIIn1 or GPOut1 is being used.

Non-isolated Ground

This ground connection must be connected to the user’s external circuit ground if GPIIn2 or GPOut2 is to be used or if the RS-232 port is to be used. Note that non-isolated Ground is common with External (power) Ground however it is good practice to provide a separate ground connection for power and signaling when designing the cabling.

Video Iris

A pulse width modulated signal can be used to drive the video input of a video iris lens. Please refer to Chapter **Video iris user circuit example** on page 33.

Reserved

These signals are reserved for future use and should be left disconnected.

Gigabit Ethernet port

The Gigabit Ethernet port conforms to the IEEE 802.3 1000BASE-T standard for Gigabit Ethernet over copper. We recommend using Category 5e or Category 6 compatible cabling and connectors for best performance.

Note



- Cable lengths up to 100 m are supported.
- The 8-pin RJ-45 jack has the pin assignment according to the Ethernet standard (IEEE 802.3 1000BASE-T).
- Cables with screw-lock connectors are available from AVT: <http://www.alliedvisiontec.com/emea/products/accessories/gige-accessories.html>

Camera I/O internal circuit diagram

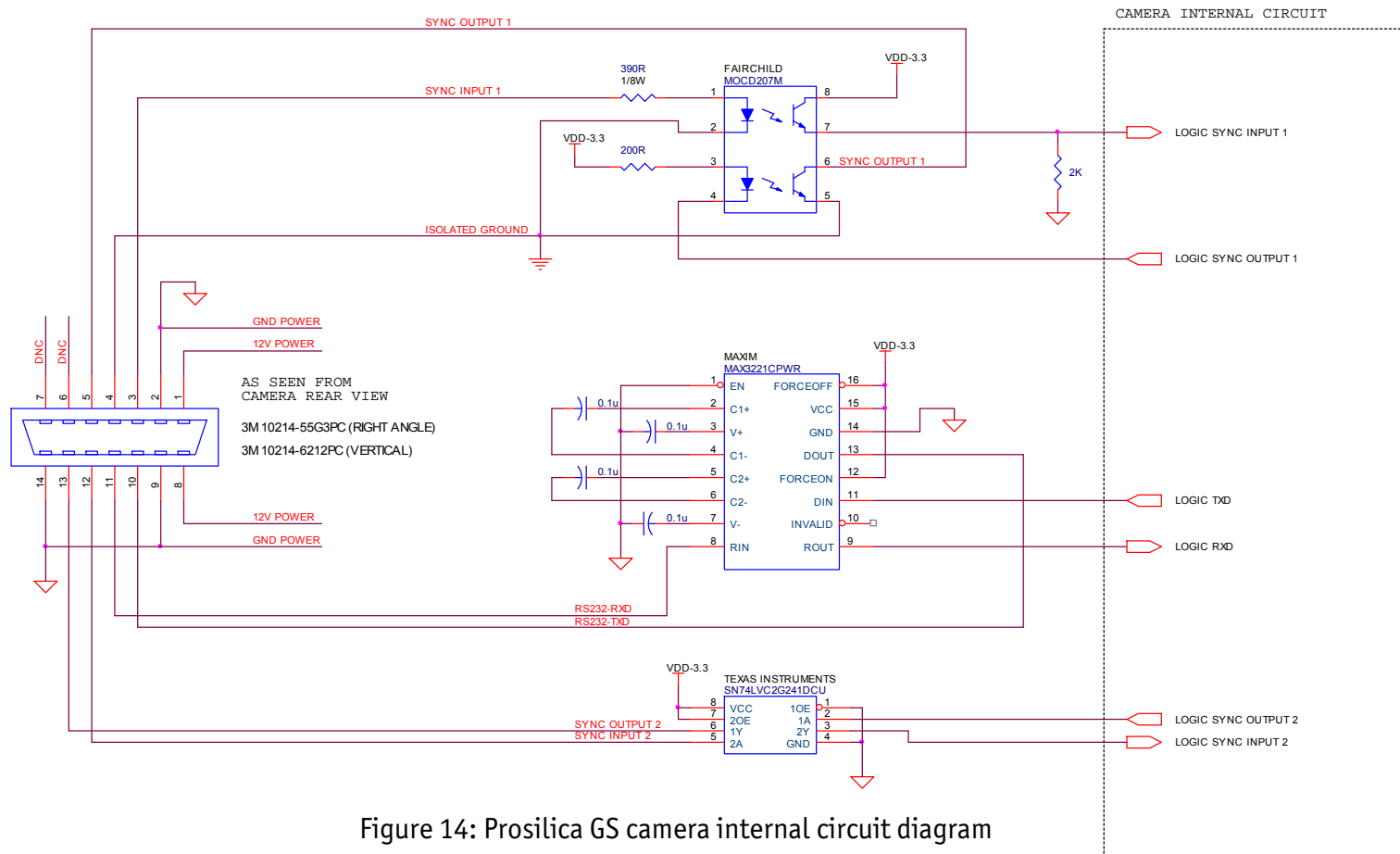

Figure 14: Prosilica GS camera internal circuit diagram

Fairchild **MOCD207**

Consist of two silicon phototransistors optically coupled to two GaAs infrared LEDs. This is the input and output of the opto isolated camera trigger

Maxim **MAX3221CPWR**

Used to drive the RS232 signal logic via the external connector

Texas Instruments **SN74LVC2G241DCE**

Used to drive the non-isolated trigger signals from the camera.

Camera I/O opto-isolated user circuit example

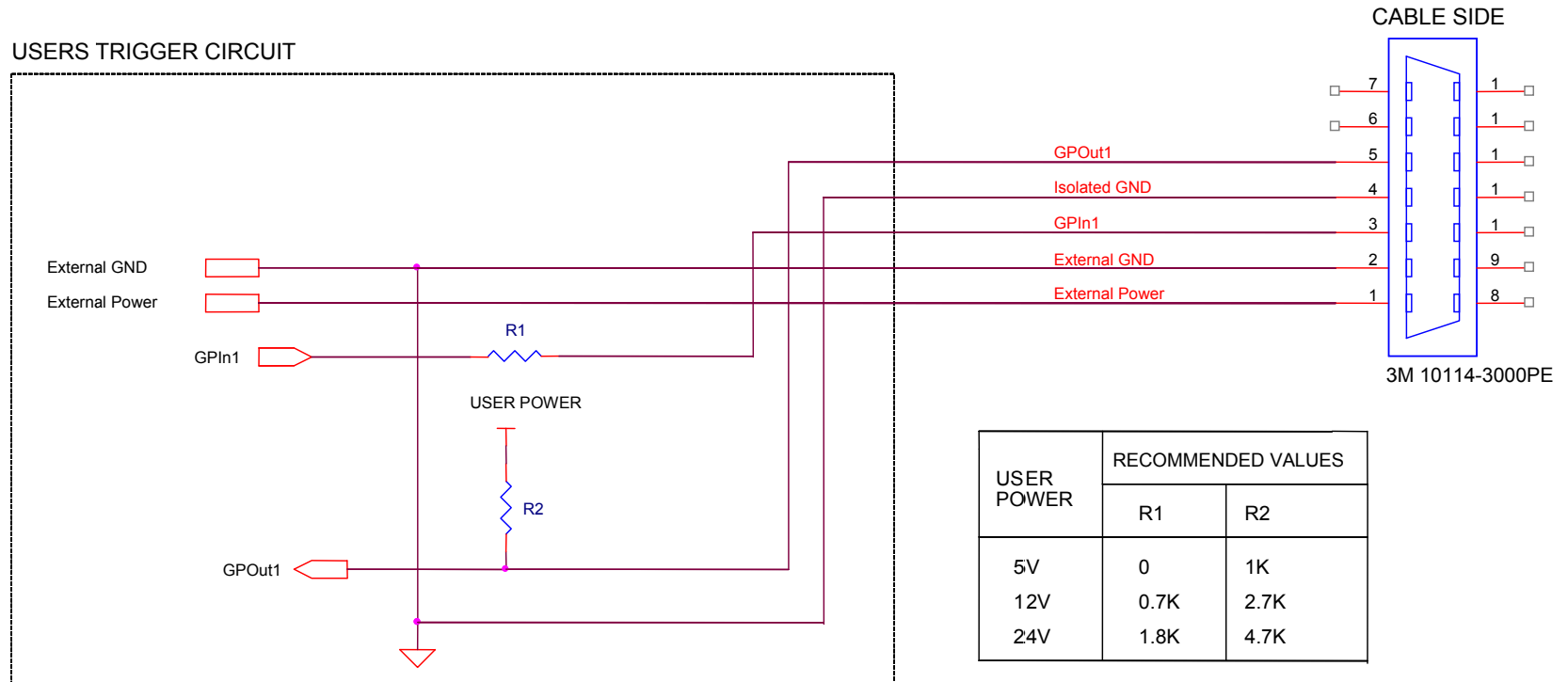

Caution



Input: Incoming trigger must be able to source 10mA. *Cameras with SN: 02-XXXXX-0XXXX, R1 necessary for > 5V input, see table above. Cameras with SN: 02-XXXXX-1XXXX, no R1 necessary, 5-24V.

Output: User power, with pull-up resistor R2 is required.

Isolated output is connected to the open collector of Fairchild MOCD207. The corresponding transistor emitter is connected to isolated ground. See the Fairchild MOCD207 datasheet for more detailed information.

Camera I/O non-isolated user circuit example

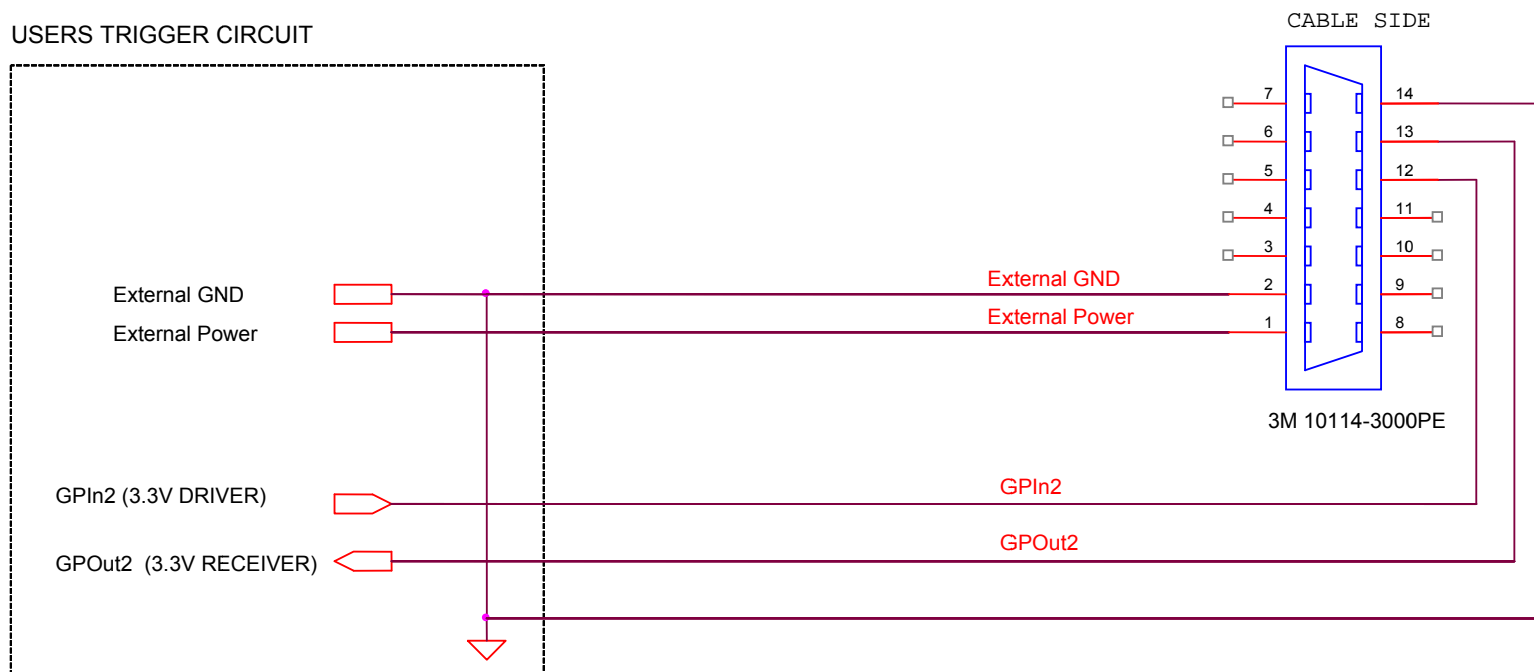

Caution



Input: Incoming trigger must be able to source 10µA, at 3.3V. Input trigger voltage of > 5.5V will damage the camera.

Output: The maximum sync output current is 24mA, at 3.3V.

The non-isolated trigger circuit is connected to a Texas Instruments SN74LVC2G241 buffer/driver inside the camera. See the Texas Instruments SN74LVC2G241 for more detailed information.

Video iris user circuit example

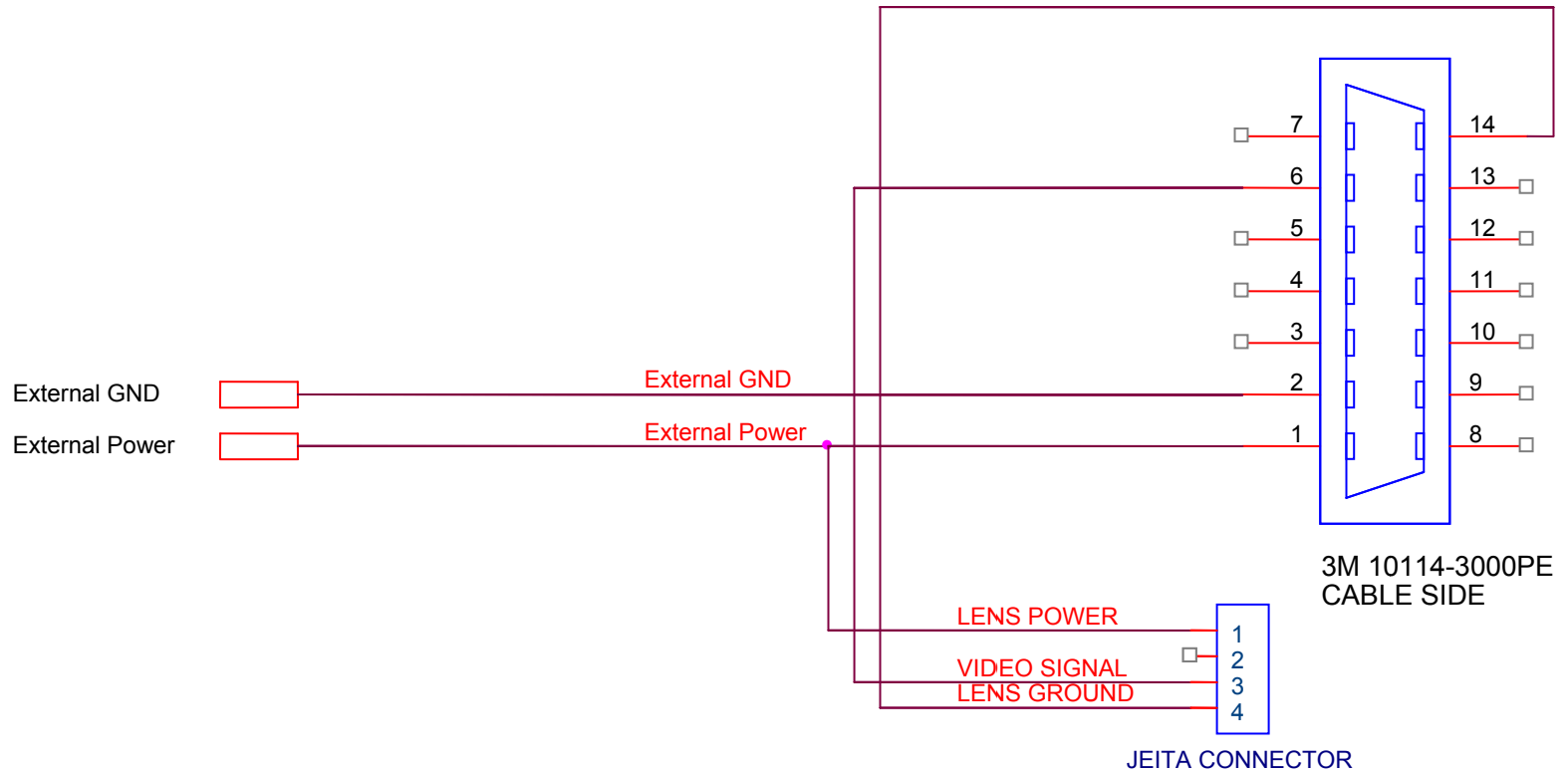

Prosilica's GS cameras provide built-in auto iris controls for controlling video-type auto-iris lenses. These lenses are available from many popular security lens companies including Pentax, Fujinon, Tamron, Schneider and others.

Note



Remote iris lens control allows the camera to be more adaptable to changing light conditions. It allows the user to manually control the exposure and gain values and rely solely on the auto iris for adjustment to ambient lighting.

Notes on triggering

Timing diagram

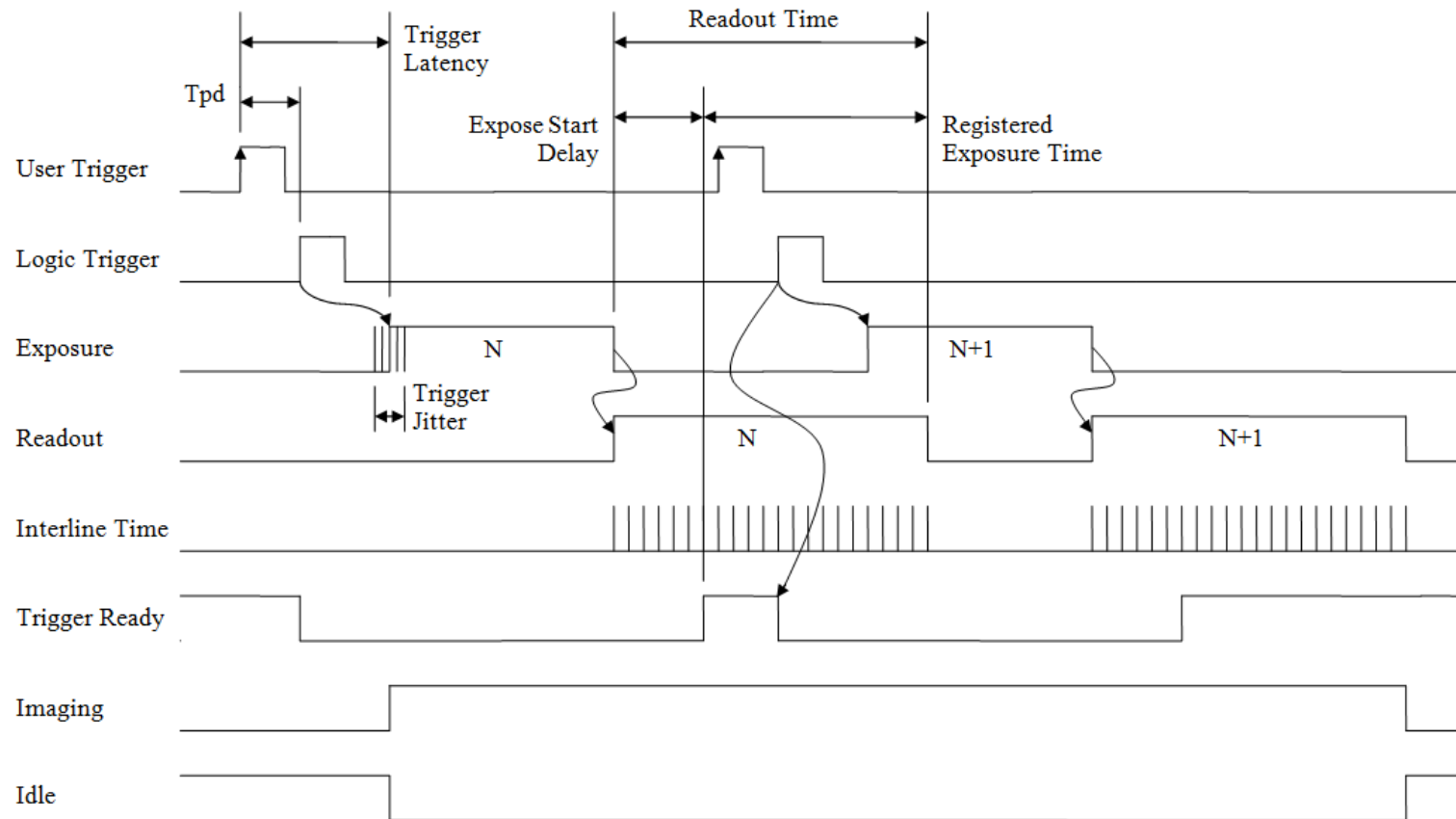

Figure 18: Prosilica GS internal signal timing waveforms

Signal definitions

Term	Definition
User Trigger	Trigger signal applied by the user (hardware trigger, software trigger)
Logic Trigger	Trigger signal seen by the camera internal logic (not visible to the user)
Tpd	Propagation delay between the User Trigger and the Logic Trigger
Exposure	... is high when the camera image sensor is integrating light.
Readout	... is high when the camera image sensor is reading out data.
Trigger Latency	Time delay between the User Trigger and the start of Exposure
Trigger Jitter	Error in the Trigger Latency Time
Trigger Ready	... indicates to the user that the camera will accept the next trigger.
Registered Exposure Time	... is the Exposure Time value currently stored in the camera memory.
Exposure Start Delay	... is the Registered Exposure Time subtracted from the Readout time and indicates when the next Exposure cycle can begin such that the Exposure will end after the current Readout.
Interline Time	... is the time between sensor row readout cycles.
Imaging	... is high when the camera image sensor is either exposing and/or reading out data.
Idle	... is high if the camera image sensor is not exposing and/or reading out data.

Table 9: Explanation of signals in timing diagram

Trigger rules

Note



The **User Trigger pulse width** should be at least three times the width of the Trigger Latency as indicated in Chapter **Specifications** on page 11

- The **end of Exposure** will always trigger the next Readout.
- The **end of Exposure** must always end after the current Readout.
- The **start of Exposure** must always correspond with the Interline Time if Readout is true.
- **Expose Start Delay** equals the Readout time minus the Registered Exposure Time.

Triggering during the Idle State

For applications requiring the shortest possible Trigger Latency and the smallest possible Trigger Jitter the User Trigger signal should be applied when Imaging is false and Idle is true.

In this case, Trigger Latency and Trigger Jitter are as indicated in the Specifications section.

Triggering during the Readout State

For applications requiring the fastest triggering cycle time whereby the camera image sensor is exposing and reading out simultaneously, then the User Trigger signal should be applied as soon as a valid Trigger Ready is detected.

In this case, Trigger Latency and Trigger Jitter can be up to 1 line time since Exposure must always begin on an Interline boundary.

Firmware update

Firmware updates are carried out via the Ethernet connection. AVT provides an application for all Prosilica GS cameras which loads firmware to the camera using a simple interface.

New feature introductions and product improvements motivate new firmware releases. All users are encouraged to use the newest firmware available and complete the firmware update if necessary.

www



Download the latest GigE firmware loader from the AVT website:
<http://www.alliedvisiontec.com/us/support/downloads/firmware.html>

Note



To determine the current firmware version loaded onto the camera, read the camera's Device Firmware attribute using **GigE Sample Viewer** or third party applications like NI's Measurement and Acquisition assistant.

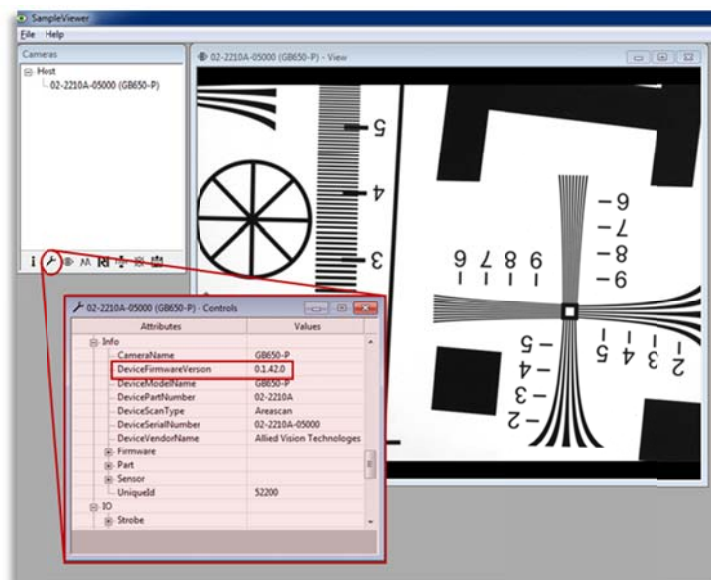

Figure 19: Screenshot of AVT GigE Sample Viewer controls window

Resolution and ROI frame rates

This section aims to provide users with performance information which identifies the impact of reducing the region of interest on the camera's maximum frame rate.

Note



- The camera frame rate can be increased by reducing the camera's Height attribute, resulting in a decreased region of interest (ROI) or "window".
- The camera frame rate can also be increased by increasing the camera's BinningY attribute, resulting in a vertically scaled image (less overall height with same field of view).
- There is no frame rate increase with reduced width
- Frame rate data was generated using StreamBytesPerSecond equals 120 MB and an 8 bit pixel format such as Mono8 or Bayer8

CAMERA: Prosilica GS650

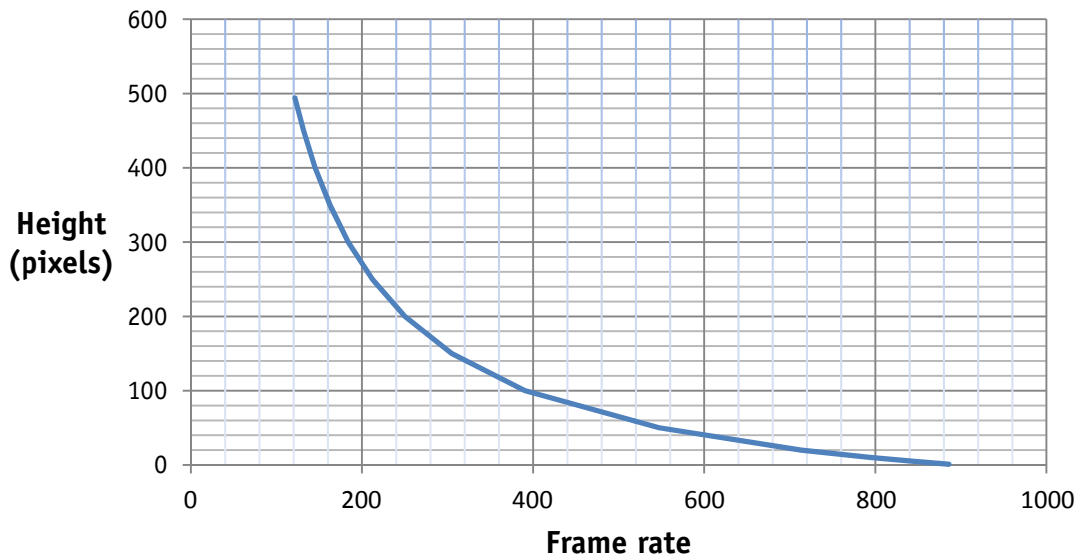

Figure 20: Maximum frame rate versus region height for GS650

CAMERA: Prosilica GS660

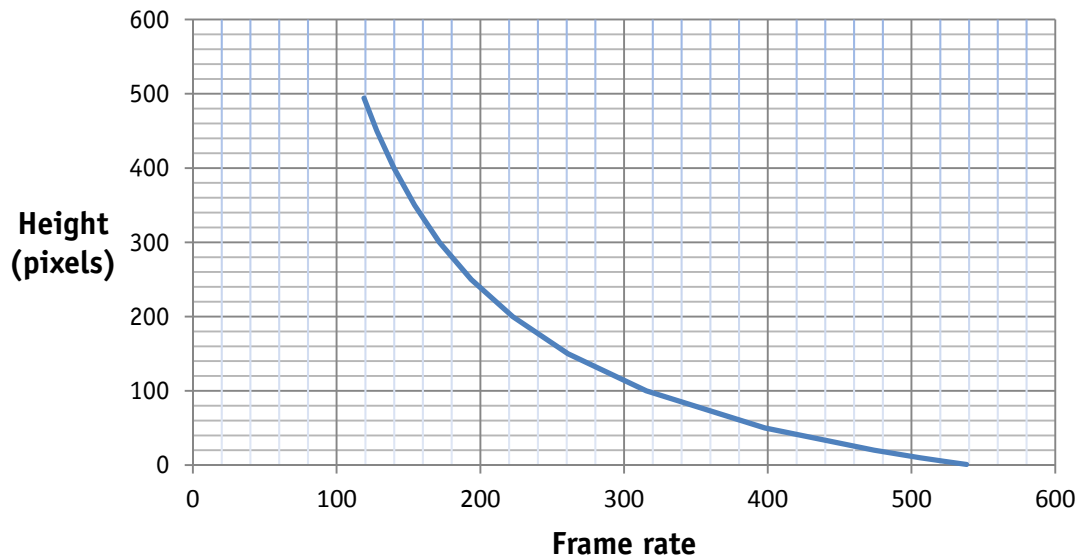

Figure 21: Maximum frame rate versus region height for GS660

CAMERA: Prosilica GS1380

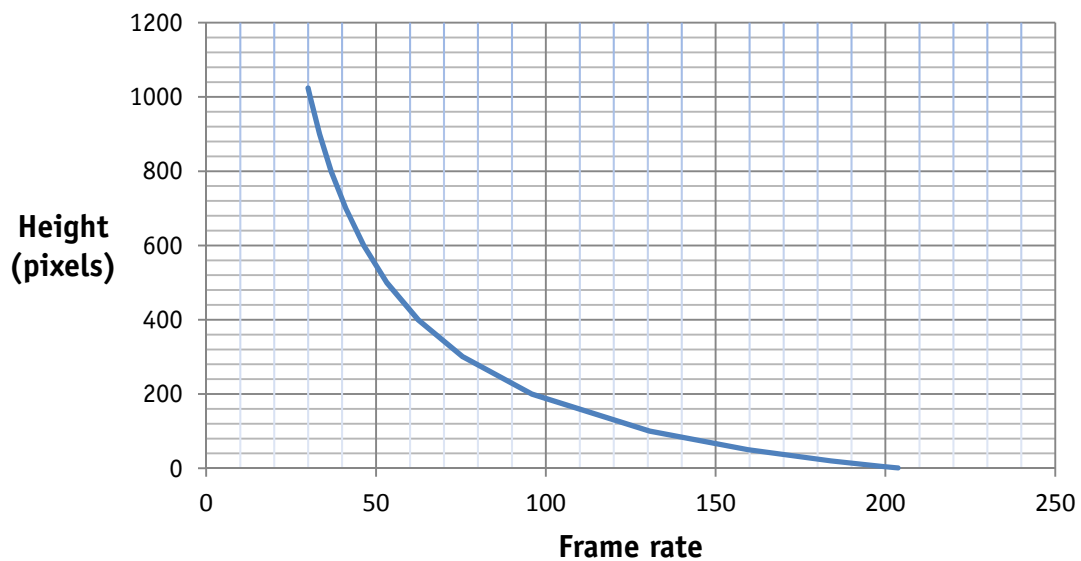

Figure 22: Maximum frame rate versus region height for GS1380

CAMERA: Prosilica GS2450

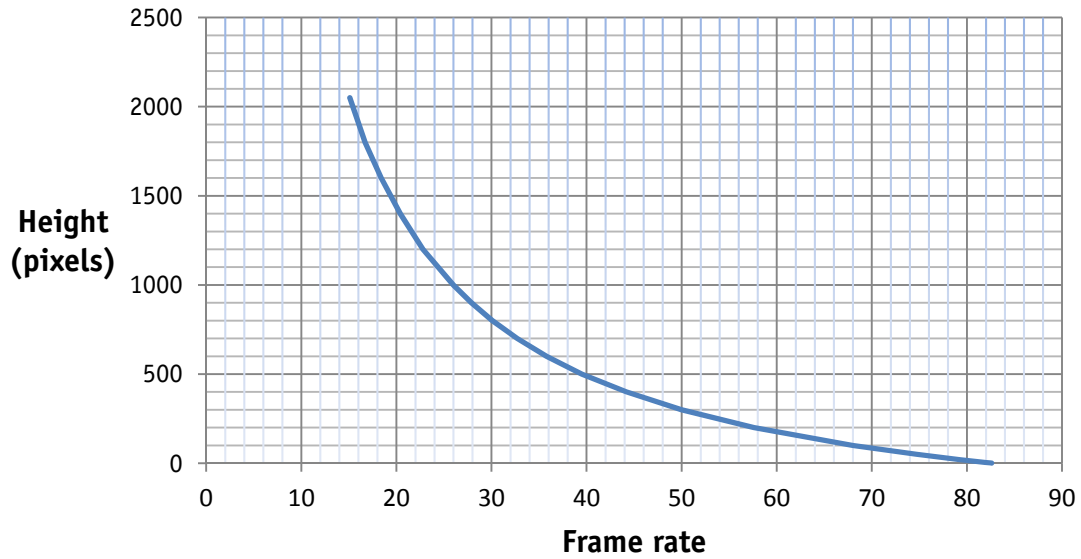

Figure 23: Maximum frame rate versus region height for GS2450

Prosilica GS family frame rate comparison

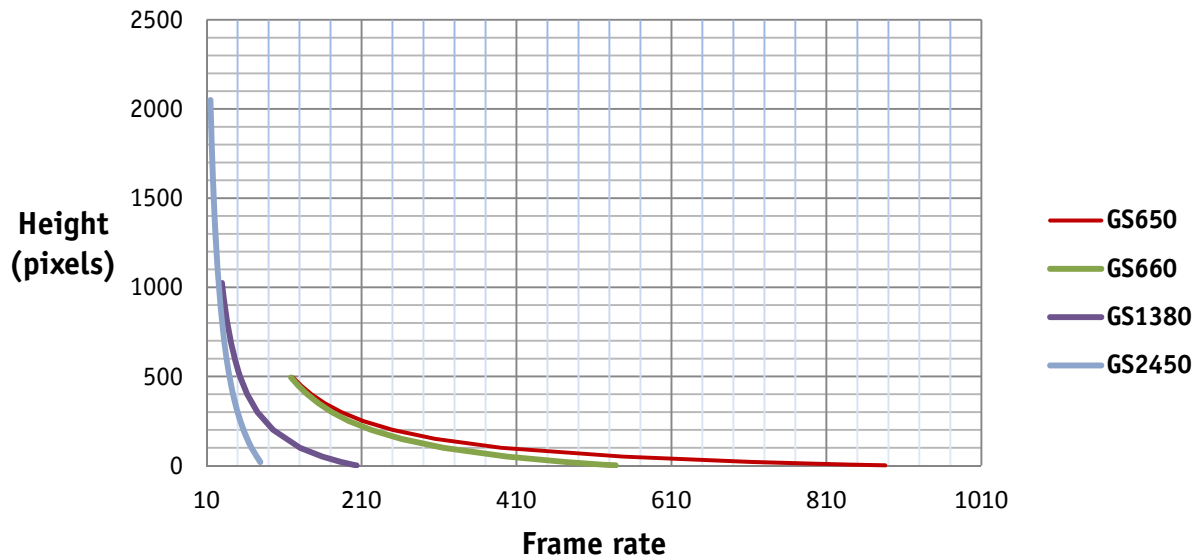

Figure 24: Maximum frame rate versus region height for all GS cameras

Additional References

Prosilica GS webpage

<http://www.alliedvisiontec.com/us/products/cameras/gigabit-ethernet/prosilica-GS.html>

Prosilica GS documentation

<http://www.alliedvisiontec.com/us/support/downloads/product-literature/prosilica-GS.html>

GigE PvAPI SDK

<http://www.alliedvisiontec.com/us/products/software/avt-pvapi-sdk.html>

Knowledge base

<http://www.alliedvisiontec.com/us/support/knowledge-base.html>

Case studies

<http://www.alliedvisiontec.com/us/products/applications.html>

Prosilica GS firmware

<http://www.alliedvisiontec.com/us/support/downloads/firmware.html>