

Prosilica GT

4096NIR



- Type APS-H CMOS sensor
- IEEE 1588 PTP
- Power over Ethernet
- 7.18 fps at full resolution

应用全能

面向高端应用的高分辨率相机

Prosilica GT 4096NIR 搭载 ON Semi PYTHON 16K NIR 传感器，在 16.7 MP 分辨率下速度可达 7.2 帧/秒。

Prosilica GT 坚固的外壳经过散热优化设计，是应对严苛环境的理想解决方案。该系列产品提供多种镜头控制模式选择，可针对不断变化的光线条件灵活调整图像亮度。其分辨率最高可达 31 MP，是对坚固性和设计灵活性要求较高的高分辨率成像应用的理想之选。

与 Allied Vision 的 **Vimba 套件** 轻松集成，并与最流行的 **第三方图像处理库** 兼容。

请参阅关于镜头接口、外壳选项、光学滤镜、外壳设计和其他模块化选项。如需特别定制，请参阅 **OEM 定制方案** 网页。

性能参数

接口	IEEE 802.3 1000BASE-T, IEEE 802.3af (PoE)
分辨率	4096 (H) × 4096 (V)
传感器	ON Semi PYTHON 16K NIR
传感器类型	CMOS
快门种类	GS (Global shutter)
传感器尺寸	Type APS-H
像元尺寸	4.5 μm × 4.5 μm
Lens mounts (available)	F-Mount
最大满帧帧率	7.18 fps
ADC	10 Bit
缓存 (RAM)	128 MByte

成像性能

Imaging performance data is based on the evaluation methods in the EMVA 1288 Release 3.1 standard for characterization of image sensors and cameras. Measurements are typical values for NIR models measured without optical filter.

在波长为 529nm 下, 量子转换效率	55 %
在波长为 850nm 下, 量子转换效率	33 %
暗噪声	28.2 e ⁻
饱和电子数	8300 e ⁻
动态范围	49.2 dB
绝对灵敏度阈值	28.8 e ⁻

输出

Bit 位数	10-bit
黑白像素格式	Mono8, Mono10

通用输入输出口 (GPIOs)

TTL I/Os	1 input, 2 outputs
光耦 I/Os	1 input, 2 outputs

工作条件/尺寸

工作温度 -20 °C to +50 °C ambient (without condensation)

电源要求 (DC) 7 to 25 VDC AUX or 802.3at Type 1 PoE

功耗 5.0 W at 12 VDC; 6.4 W PoE

重量 372 g

尺寸 (L × W × H in mm) 96 × 66 × 53.3 (including connectors)

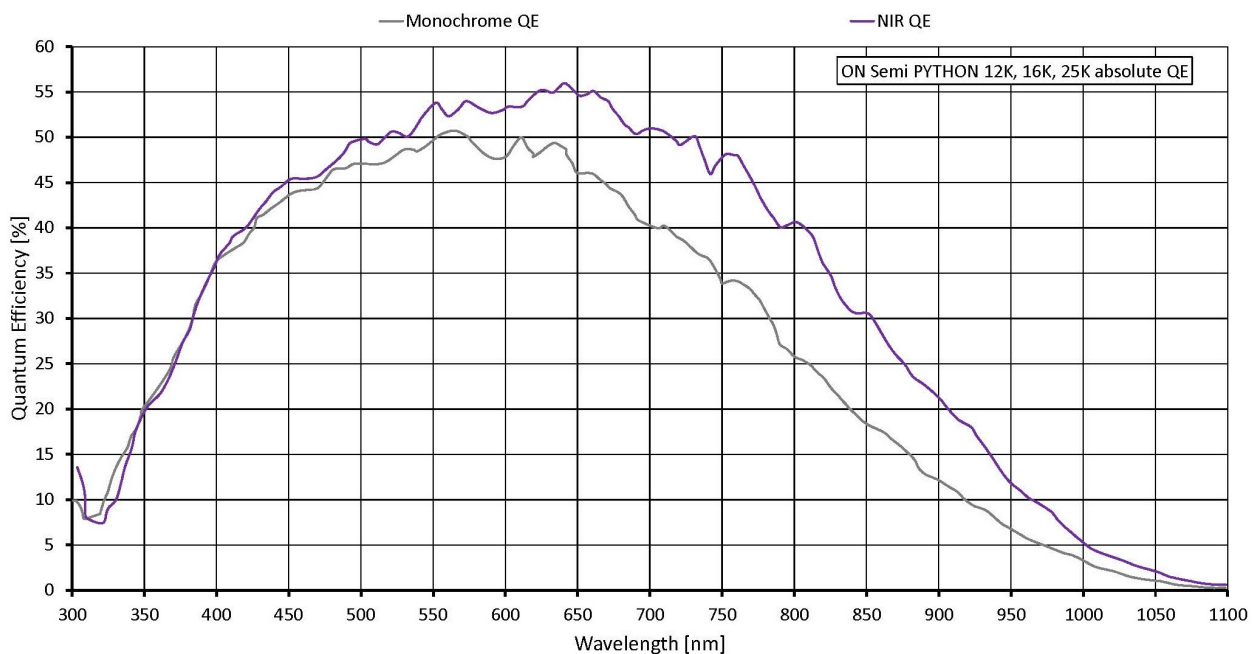
量子转换效率

特性

Image optimization features:

- Auto gain (manual gain control: 0 to 22 dB)
- Auto exposure (manual exposure control: 1 μ s to 1 s, 1 μ s increments)
- Binning (horizontal and vertical) (sum)
- Decimation X/Y
- Enhanced Defect Pixel Correction
- Fixed Pattern Noise Correction
- Gamma correction
- Three look-up tables
- Region of interest

Camera control features:

- EF lens control (order option -18)
- Event channel
- Image chunk data
- IEEE 1588 Precision Time Protocol
- RS232
- Storable user sets
- StreamBytesPerSecond (bandwidth control)
- Stream hold
- Sync out modes: Trigger ready, input, exposing, readout, imaging, strobe, GPO
- Temperature monitoring (main board and sensor board)
- Trigger over Ethernet Action Commands

外形尺寸

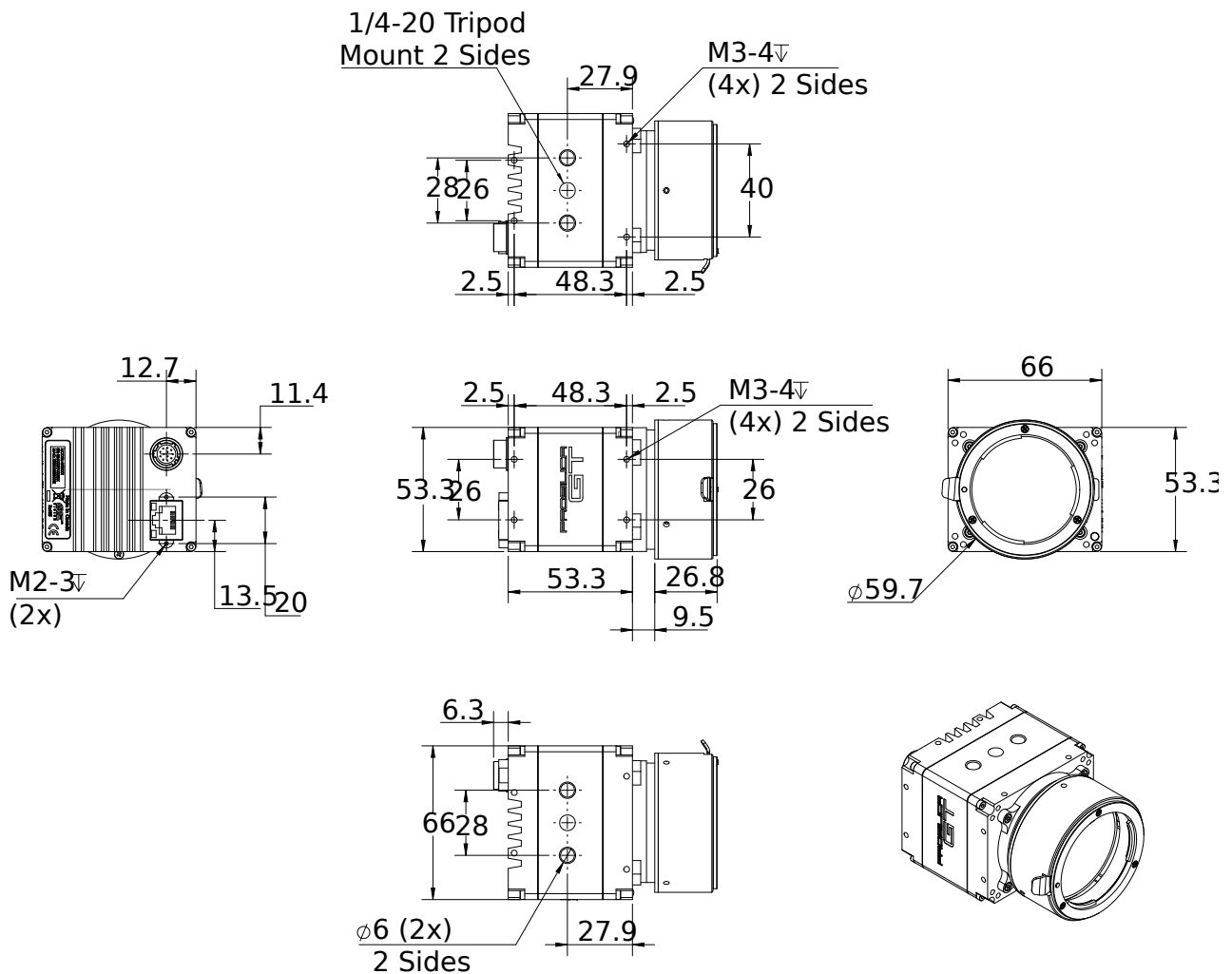

应用场景

Prosilica GT4096NIR is ideal for a wide range of applications including:

- Outdoor imaging
- Intelligent Traffic Systems
- Public security and surveillance
- Industrial inspection (for example food, bottles, recycling, labels)
- Microscopy
- Military and space applications
- Medical and healthcare
- Other machine vision applications