

Prosilica GT

1660



- Versatile temperature range for extreme environments
- PTP
- PoE
- P-Iris and DC-Iris lens control

应用全能

面向高端应用的高分辨率相机

Prosilica GT 1660 搭载 ON Semi KAI-02050 传感器，在 1.9 MP 分辨率下速度可达 62.1 帧/秒。

Prosilica GT 坚固的外壳经过散热优化设计，是应对严苛环境的理想解决方案。该系列产品提供多种镜头控制模式选择，可针对不断变化的光线条件灵活调整图像亮度。其分辨率最高可达 31 MP，是对坚固性和设计灵活性要求较高的高分辨率成像应用的理想之选。

与 Allied Vision 的 **Vimba 套件** 轻松集成，并与最流行的 **第三方图像处理库** 兼容。

请参阅关于镜头接口、外壳选项、光学滤镜、外壳设计和其他模块化选项。如需特别定制，请参阅 **OEM 定制方案** 网页。

性能参数

接口	IEEE 802.3 1000BASE-T, IEEE 802.3af (PoE)
分辨率	1600 (H) × 1200 (V)
传感器	ON Semi KAI-02050
传感器类型	CCD Progressive
快门种类	GS (Global shutter)
传感器尺寸	Type 2/3
像元尺寸	5.5 μm × 5.5 μm
Lens mounts (available)	C-Mount, CS-Mount, F-Mount, M42-Mount
最大满帧帧率	62.1 fps
ADC	14 Bit
缓存 (RAM)	128 MByte

成像性能

成像性能数据是基于欧洲机器视觉协会 (EMVA) 1288 发布的 3.1 版图像传感器和像机特征描述标准中的评估方法。测量值是在没有光学滤波片的全分辨率下，测量单色模型的典型值。请联系销售或工程师了解更多信息。

在波长为 529nm 下，量子转换效率 42 %

暗噪声 16.4 e⁻

饱和电子数 18900 e⁻

动态范围 61.0 dB

绝对灵敏度阈值 16.9 e⁻

输出

Bit 位数 12-bit or 14-bit

黑白像素格式 Mono8, Mono12, Mono12Packed, Mono14

通用输入输出口 (GPIOs)

TTL I/Os 1 input, 2 outputs

光耦 I/Os 1 input, 2 outputs

RS232 1

工作条件/尺寸

工作温度 -20 °C to +60 °C ambient (without condensation)

电源要求 (DC) 7 to 25 VDC AUX or 802.3at Type 1 PoE

功耗 5.1 W at 12 VDC; 6.3 W PoE

重量 224 g

尺寸 (L × W × H in mm) 92 × 53.3 × 33 (including connectors)

量子转换效率

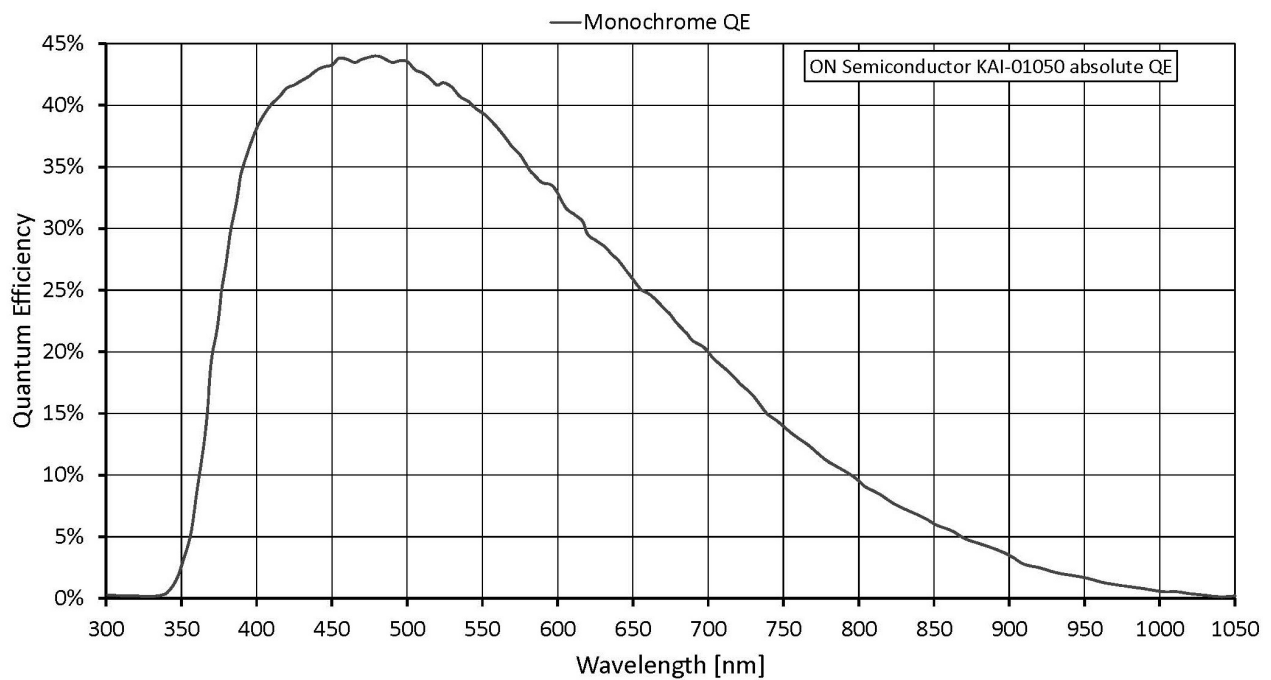

特性

Image optimization features:

- Auto gain (manual gain control: 0 to 32 dB)
- Auto exposure (manual exposure control: 10 μ s to 26.8 s)
- Binning (horizontal and vertical)
- Column defect masking
- Decimation X/Y
- Gamma correction
- Three look-up tables (LUTs)
- Region of interest (ROI), separate ROI for auto features
- Reverse X/Y

Camera control features:

- P-Iris and DC-Iris lens control
- Event channel
- Image chunk data
- IEEE 1588 Precision Time Protocol (PTP)
- RS232
- Storable user sets
- StreamBytesPerSecond (bandwidth control)
- Stream hold
- Sync out modes: Trigger ready, input, exposing, readout, imaging, strobe, GPO
- Tap mode switchable in Vimba Viewer 2.0 or later (four-tap, one-tap)
- Temperature monitoring (main board and sensor board)
- Trigger over Ethernet (ToE) Action Commands
- Non-volatile memory 1024 KByte (for selected models only)

外形尺寸

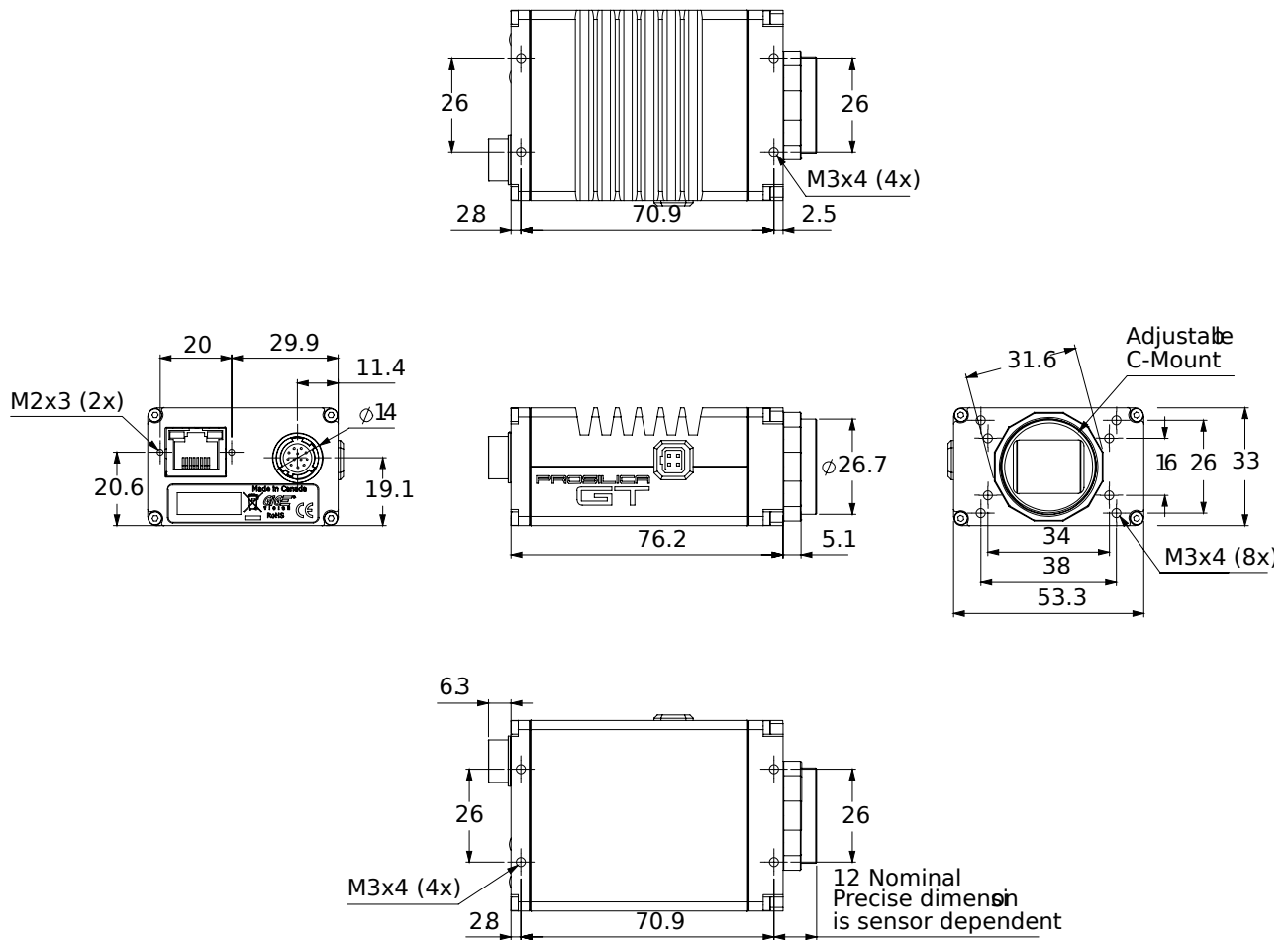

应用场景

Prosilica GT1660 is ideal for a wide range of applications including:

- Outdoor imaging
- Traffic imaging and ITS
- Public security and surveillance
- Industrial inspection
- Machine vision
- Military and space applications