

Application Note

Connecting IEEE 1394 devices safely to maximize operating lifetime

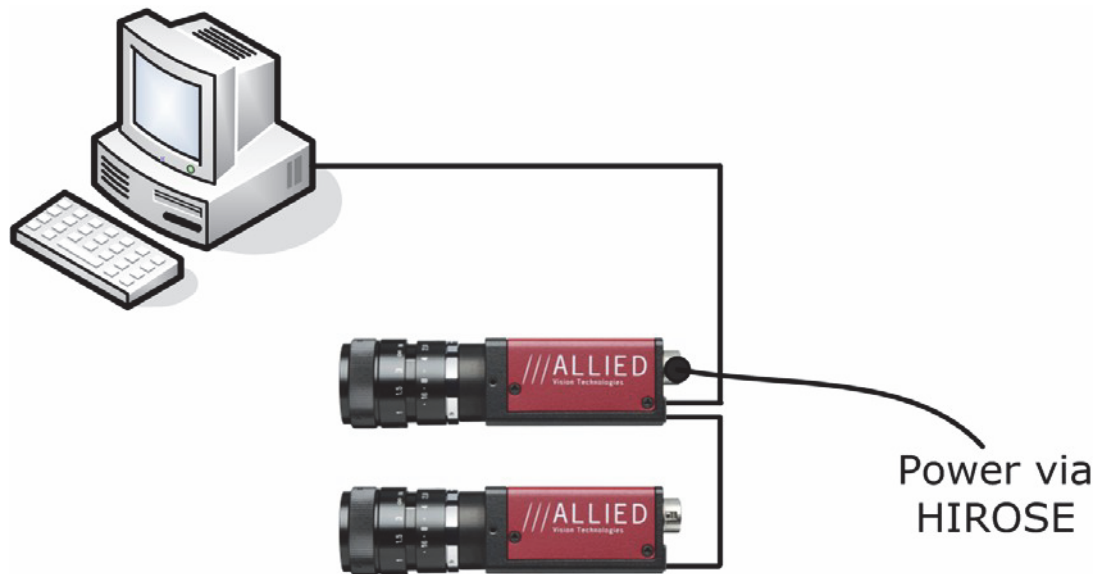

Scope of this document

Topic

In this application note you learn step by step which actions should be done when connecting 1394 digital cameras.

This application note describes the following:

Contents

- [Term description](#) on page 3
- [What is a 1394 PHY damage?](#) on page 3
- [Reasons for 1394 PHY damage \(single- camera and multi-camera applications\)](#) on page 4
- [Avoiding 1394 PHY damage](#) on page 5
- [Additional discussions for specialists with deep electrotechnical background](#) on page 11A

Target group

(Electrical) engineers and technicians (with electrotechnical education) who want to avoid 1394 PHY damages in single-camera and multi-camera applications using 1394 digital cameras.

Term description

First we explain some terms. This will help in understanding this application note. For those of you who want a deeper technical discussion, some weblinks are provided.

PHY: A **1394 PHY** is an electronic integrated circuit which sends signals to the 1394 bus and receives signals from the 1394 bus.

Inrush current: The maximum, instantaneous input current drawn by an electrical device when first turned on. The inrush current is usually higher than the nominal current.

ESD: Abbreviation for electrostatic discharge. ESD is the sudden and momentary flow of electrical current between two objects at different electrical potentials.

For a deep discussion of ESD see http://en.wikipedia.org/wiki/Electrostatic_discharge

Late Vg: Vg is cable ground (cable GND). Due to a delayed contact of ground pin (GND) a current takes the wrong way over data lines (instead of power line) and may damage the inputs of the 1394 PHY devices on **both** sides of the cable.

For a deep discussion see <http://focus.tij.co.jp/jp/lit/an/slea072a/slea072a.pdf>

GND = ground

VCC = positive supply voltage

Latch-up: This means that due to inrush current / cable resistors / additional loads the GND potential jumps e.g. from 0 V to 1.0 V and is therefore higher than the potential of the data lines (0.5 V). This leads to a damage of the 1394 PHY device.

For a deep discussion of latch-up see <http://en.wikipedia.org/wiki/Latch-up>

Daisy chain: Original meaning: a daisy garland created from daisy flowers. From this the meaning in FireWire technology is derived: Two or more FireWire cameras connected in series. Each FireWire camera has two FireWire connectors. The first camera is connected to the PC, the second camera is connected to the first camera, the third camera to the second and so on.

What is a 1394 PHY damage?

A 1394 PHY damage means the physical damage of a 1394 PHY device. The microstructures (silicon) of electronic components are very sensitive, so that small overvoltage or little higher electrical currents will lead to localized heating, that means evaporation of the material. This can happen under certain circumstances which are explained in the following section.

Reasons for 1394 PHY damage (single- camera and multi-camera applications)

The following reasons are responsible for a 1394 PHY damage:

Reason	Description
1. Late Vg by hot-plug	Putting plug and receptacle together in a typical hot-plug system, GND and Cable GND have contact before data lines. If this is not the case (e.g. when plugging under extreme angles or using distressed plugs/receptacle), a current takes the wrong way over data lines (instead of power line) and may damage the inputs of the 1394 PHY devices on both sides of the cable.
2. Latch-up	The latch-up effect can be caused by the following: inrush current, cable resistors, additional loads.
3. ESD	By hot-plugging a camera and PC via 1394 cable, ESD can happen: e.g. if the PC is badly grounded, electrical charge can be forced to <i>jump</i> via the cable into the camera. This may lead to a 1394 PHY damage.
4. Cable length	Cable length is a crucial factor for 1394 PHY damage in connecting PC and camera. Depending on the single- or multi-camera application a cable, that is too long increases the possibility for 1394 PHY damage.
5. Cable quality	Low cable quality means that junction resistance of the plug is too high is too high and therefore the potential drop is also too high. This may also lead to 1394 PHY damage.

Avoiding 1394 PHY damage

All scenarios (single + multi)

In all scenarios (single-camera applications as well as multi-camera-applications) the customer is responsible for the following actions:

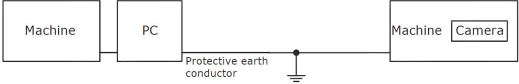
Situation/problem	Customer action	Drawings and images
0. Before connecting	<p>All systems have to be without power, before connecting them with FireWire cable:</p> <ul style="list-style-type: none"> • Switch off PC • Switch off machines • Switch off digital camera(s) 	
1. Plugging	<ul style="list-style-type: none"> • Always plug in a way that GND and Cable GND have contact before data lines (see images in the right column). • Avoid using 1394 plugs under extreme angles. • Avoid using distressed plugs/receptacles 	
2. ESD	<ul style="list-style-type: none"> • PC, machine and digital camera must have same ground. • When combining two systems (e.g. machine/PC and machine/camera), both systems must have the same potential: • Use a protective earth conductor (PE cable that has sufficient diameter) • Use a low-resistance and low-inductive connection 	

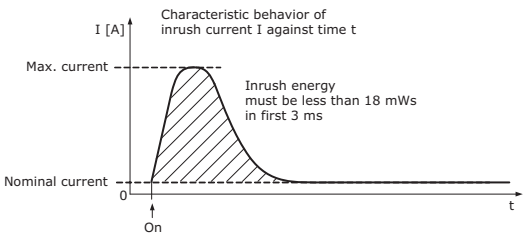
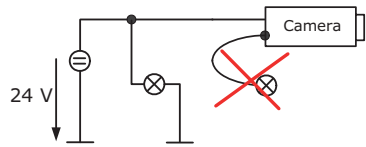
Situation/problem	Customer action	Drawings and images
<p>3. Inrush current / inrush energy</p>	<p>By switching on a 1394 device, keep inrush energy as low as possible and take care on the following necessary conditions (due to FireWire specification):</p> <ul style="list-style-type: none"> • In single-camera application: the inrush energy of the camera must be below 18 mWs in the first 3 ms. • In multi-camera applications: Due to FireWire specification the sum of inrush energy of all cameras must be below 18 mWs in the first 3 ms. 	
<p>4. Flash box or devices with high current demand/ high input capacitors</p>	<ul style="list-style-type: none"> • Don't use flash box in daisy chain connection. • Only use flash box with own power supply. • If you nevertheless want to use only one power supply, then use large enough lead resistance, e.g. 100 Ω or more. 	 <p>Don't use flash box in daisy chain connection.</p>

Situation/problem	Customer action	Drawings and images
<p>5. Cable length</p>	<p>Depending on the number of digital camera used, minimize the cable length from PC to Camera according to the drawings in the right column. (in two-camera application: Minimize the cable length from PC to Camera1.)</p> <p>Copper: only cable length up to 10 m are specified for proper operation. High grade long distance cable for IEEE 1394b from Allied Vision can be used up to 15 m but only in single-camera applications.</p> <p>GOF: cable length up to 100 m are specified for proper operation.</p> <p>See also more detailed advices in subsections:</p> <p>Topology: 2 cameras on page 10</p> <p>Topology: 3 cameras on page 10</p> <p>Topology: 4 cameras on page 11</p>	

Situation/problem	Customer action	Drawings and images
6. Cable quality	<ul style="list-style-type: none"> Only use high-quality cables up to 10 m (order number K1200262). High grade long distance cable for IEEE 1394b, from Allied Vision (order number K1200291) can be used up to 15 m (only single-camera application). <p>High-quality cables have: c:> Lower line resistance specially for ground</p>	 <p>Allied Vision high grade long distance cable for IEEE 1394b</p>
7. Chassis GND	Do not connect Chassis GND with GND.	

Additional actions for multi-camera scenarios only

In multi-camera applications the customer is responsible for the following additional actions:

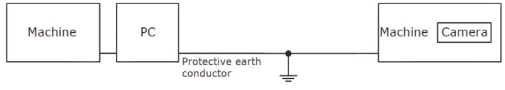
Situation/problem	Customer action	Drawings and images
1. Power supplies	Take care that all power supplies have the same GND.	
2. Power supplies	Use galvanic isolation to Chassis GND / GND of PC of all power supplies (more theoretical)	
3. Power supplies	Force potential equalization between the systems by low-resistance and low- impedance connection	

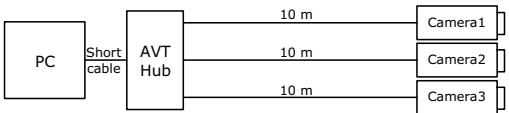
Situation/problem	Customer action	Drawings and images
<p>4. Daisy chain</p>	<p>Rule of thumb:</p> <ul style="list-style-type: none"> • Power one of the (two/three/four) daisy chained cameras with external power supply. • Always use external power supply voltage that overwrites PC power supply on the one hand (min. 15 V) and that is not too high (not much more than 24 V). <p>For correct powering of Daisy chained cameras see:</p> <p>Topology: 2 cameras on page 10</p> <p>Topology: 3 cameras on page 10</p> <p>Topology: 4 cameras on page 11</p>	
<p>5. External hub</p>	<p>Alternatively to daisy chain you can use an Allied Vision hub to power two or more cameras.</p> <ul style="list-style-type: none"> • Use short cable between PC and Allied Vision hub. • Use long copper cables up to 10 m between Allied Vision hub and the cameras. 	<p>Example for using an Allied Vision hub:</p>  <pre> graph LR PC[PC] --- Short cable AVT[AVT Hub] AVT --- 10 m Cam1[Camera1] AVT --- 10 m Cam2[Camera2] AVT --- 10 m Cam3[Camera3] </pre>

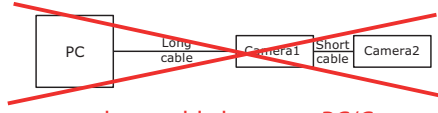
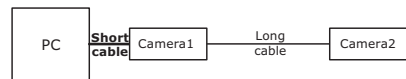
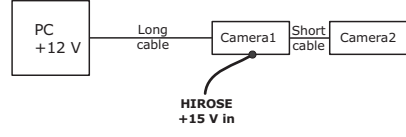
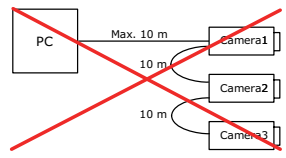
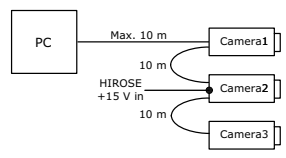
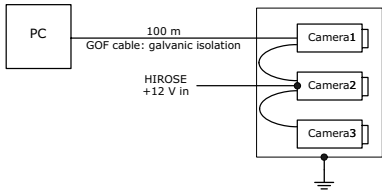
Situation/problem	Customer action	Drawings and images
<p>6. Topology: 2 cameras</p>	<p>Camera1 is susceptible for 1394 PHY damage:</p> <ul style="list-style-type: none"> Minimize cable length from PC to Camera1 or Use external power supply. <p>Technical background for specialists: Two-camera scenario on page 11</p>	 <p>Do not use long cable between PC/Camera1 without external power.</p>  <p>Use short cable between PC/Camera1</p> <p>or</p>  <p>If using long cable between PC/Camera1: Power Camera1 via HIROSE.</p>
<p>7. Topology: 3 cameras</p>	<p>Camera1 is susceptible for 1394 PHY damage:</p> <ul style="list-style-type: none"> Power Camera2 via HIROSE or Power Camera2 via HIROSE and use GOF cable and force potential equalization of all 3 cameras. 	 <p>Do not use daisy chaining without external power.</p>  <p>In 3-camera application always power Camera2 via HIROSE.</p> <p>or</p>  <p>Power Camera2 via HIROSE and additionally use a GOF cable up to 100 m between PC/Camera1 and take care that all three cameras have the same potential.</p>

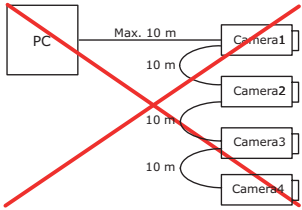
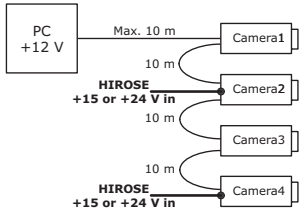
Situation/problem	Customer action	Drawings and images
<p>8. Topology: 4 cameras</p>	<p>Camera1 is susceptible for 1394 PHY damage:</p> <ul style="list-style-type: none"> • Power Camera2 via HIROSE or • Power Camera2 and Camera4 via HIROSE and take care that Camera2/Camera4 have the same potential. If using 2 power supplies, take care that PC and both power supplies have the same potential. <p>Technical background for specialists: Scenario with 4 cameras on page 13</p>	 <p>Do not use daisy chaining without external power.</p>  <p>Power Camera2 and Camera4 via HIROSE and take care that Camera2/Camera4 have the same potential .</p> <p style="text-align: center;">.</p> <p style="text-align: center;">.</p> <p style="text-align: center;">.</p>

Additional discussions for specialists with deep electrotechnical background

Two-camera scenario

Scenario: PC and two cameras in daisy chain configuration without external power

Question: Which camera is more likely to have trouble with 1394 PHY damage?

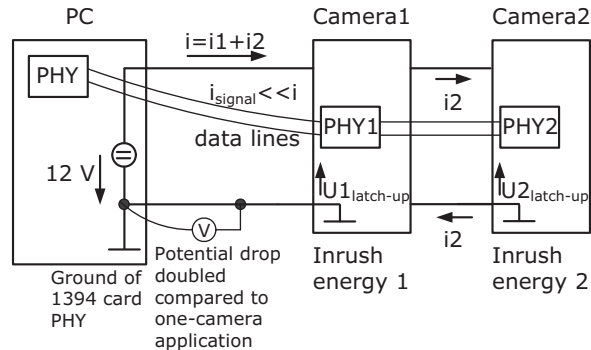

Figure 1: Two camera scenario with power from PC

Discussion:

PC has the ground potential of the 1394 card PHY.

Now let us discuss the multi-camera situation in detail, to find out whether camera 1 or camera 2 is more likely to have trouble with 1394 PHY damage:

- Potential of data lines in PHY 1 is near 0 V. (Reason: $i_{signal} \ll i$)
- Potential of data lines in PHY 2 is potential of the Camera1 GND.
- Potential of the camera GND depends on current $i=i_1+i_2$. Therefore ground will be latched-up in the camera. In Camera2 this effect is greater than in Camera1.
- PHY2 has reference potential Ground from Camera1 and not Ground of 1394 card PHY. Therefore the latch-up effect $U_{2,latch-up}$ from Camera2 is smaller than $U_{1,latch-up}$ from Camera1. In general: $U_{latch-up}$ depends on i while using same cable lengths.

c:> **Conclusion:** Camera1 is more likely to have trouble with 1394 PHY damage than Camera2.

Daisy chaining with power over HIROSE

Scenario: PC and two 1394b cameras in daisy chain configuration with external power via HIROSE

Question: What can be said about the potential situation, which camera should be powered and what is the advantage compared powering via PC?

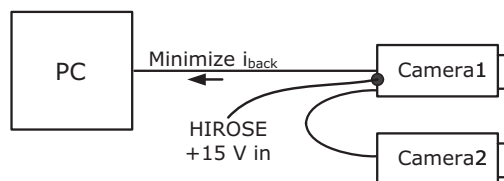

Figure 2: Schema of Daisy Chaining and HIROSE

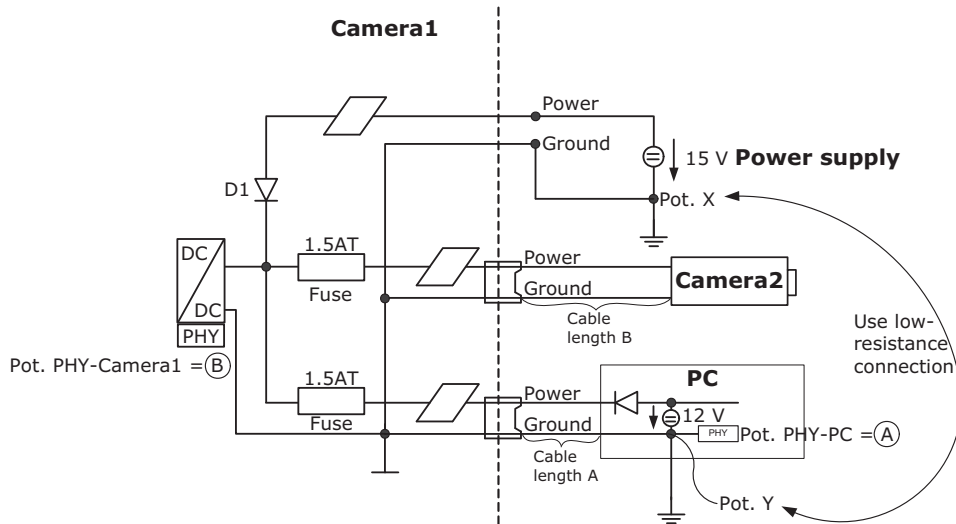

Figure 3: Details of Daisy Chaining and HIROSE

Discussion:

The general FireWire situation (PC, Camera1 powered via HIROSE, Camera2) is the following:

The device delivering the highest input voltage is the winning one. Having a PC with +12 V we recommend using a HIROSE input voltage of e.g. + 15 V.

Recommendations for the power supply (+ 15 V):

- Must have galvanic isolation to Chassis GND / GND of PC (more theoretical)
- Potential X = Potential Y (more practical): Force potential equalization by low-resistance and low-impedance connection

Further recommendations:

- D1 max. 2 A.
- Potential A = Potential B c:>cable length is not essential

c:> **Conclusion:** Powering Camera1 via HIROSE has the big advantage, that cable between PC and Camera1 can be longer than in case of powering via PC.

Scenario with 4 cameras

Scenario: PC and four 1394b cameras in daisy chain configuration with external power via HIROSE

Question: What can be said about the potential situation, which camera should be powered and what are the main influences for the voltage drop?

Discussion:

The aim is to distribute the return currents (i_{back1} , i_{back2}) in a manner, so that $i_{back1} \approx i_{back2}$.

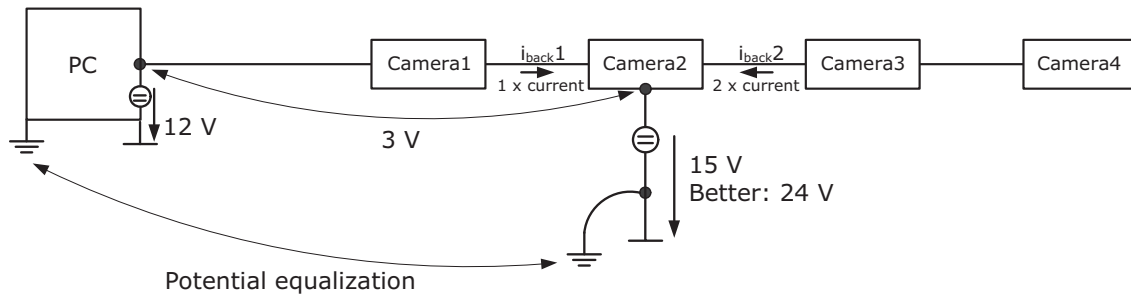

Figure 4: Scenario with more than 3 cameras

c:> **Conclusion:** In this scenario have a close look to the following 4 influences that lead to a voltage drop of 3 V in Fig. 4:

1. resistance of the cable
2. junction resistance of the plug
3. resistance of filter and conductor path
4. internal reverse polarity diodes

What about powering with 36 V?

Although a nominal voltage of 36 V would be ok, you will get in trouble with a too high inrush current.

Therefore only use 36 V if it is absolutely necessary.

The reason is: By switching the 1394 device on, the inrush current depends on the voltage. Greater voltage means more inrush current and this leads to high current on ground.

For technical support, please contact support@alliedvision.com.

For comments or suggestions regarding this document, please contact info@alliedvision.com.

Disclaimer

Due to continual product development, technical specifications may be subject to change without notice. All trademarks are acknowledged as property of their respective owners. We are convinced that this information is correct. We acknowledge that it may not be comprehensive. Nevertheless, Allied Vision Technologies ("Allied Vision") cannot be held responsible for any damage in equipment or subsequent loss of data or whatsoever in consequence of this application note.

Copyright © 2009

This document was prepared by the staff of Allied Vision and is the property of Allied Vision, which also owns the copyright therein. All rights conferred by the law of copyright and by virtue of international copyright conventions are reserved to Allied Vision. This document must not be copied, or reproduced in any material form, either wholly or in part, and its contents and any method or technique available therefrom must not be disclosed to any other person whatsoever without the prior written consent of Allied Vision.